

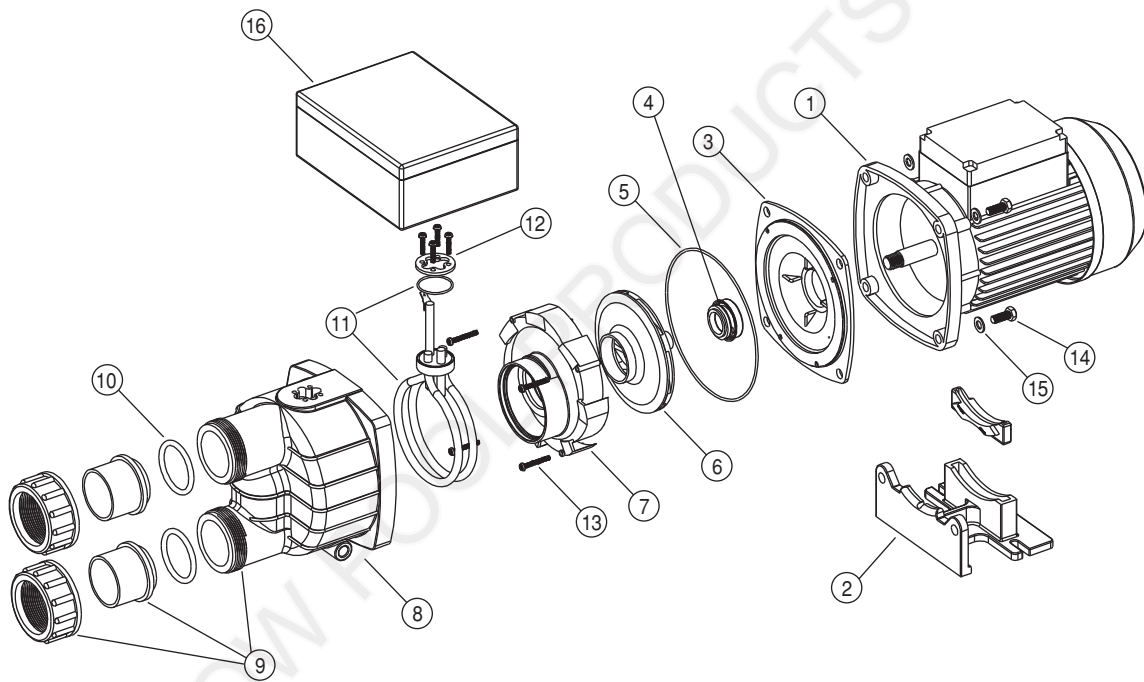

Quality Pool & Spa Products

## PORTAPAC MK2

### SPARE PARTS DIAGRAM



Key	Description	Product Code
1	Motor 1.17kW	6307245
2	Pump Foot	AXPU158
3	Adaptor Plate	63506300
4	Mechanical Seal SS316	6340162
5	O ring Pump Body	S1226911
6	Impeller (4555140, 142, 144, 1490)	635097
6	Impeller (4555141, 143, 146, 148)	635099
7	Diffuser Mk2	638153
8	Pump Body Mk2	638152
9	Half Union 40mm C/W O ring	122243B
10	40mm Union O ring	64479
11	Element 1.6kw Mk2 C/W O ring (4555140, 142, 144, 1490)	636138681
11	Element 2.4kw Mk2 C/W O ring (4555141, 143, 146, 148)	636138691
11	O ring element BS027 Nitrile 70	63813920
12	Profile Washer S/S	63813899
13	Screw M4x32mm PT SS316	63400832
	M8 Multi Pack Bolts & Washers	63401812
14	4 x 6350530 (M8 x 30 bolt)	
15	4 x 6302180 (M8 washer)	
16	Control Box With 10A Plug & Cord (4555140)	6381603
16	Control Box With 15A Plug & Cord (4555141)	6381602
16	Control Box SSC Premium Boost	6381614
16	Control Box SSC Air - Compact	6381615
16	Control Box SSC Boost - Compact	6381616
16	Lid Control Box (suit 6381602/6381603)	S138631
16	Bottom Control Box (suit 6381602/6381603)	S138621
n/s	Bolt M6x20 Hex Set SS316 (motor/foot)	6340040
n/s	Temperature Sensor MK2	64130032
n/s	Housing Assembly Temperature Sensor Mk2	6381620
n/s	O/T Sensor Mk2	638172
n/s	Pressure Switch	6367237
n/s	Air Control Switch	63813913
n/s	Touch Pad Complete (4555142, 143)	455512611
n/s	Touch Pad Complete (4555144, 146)	45551285
n/s	Touch Pad Complete (4555148, 1490)	455512812
	Screw M4x20 Pan Head (element, 2 required)	S1348415
	Screw M4x25 Pan Head Phillips 304 (element, 2 required)	634037
	Washer Star 5/32 304 (element, 4 required)	S0972315
	Washer (element, 2 required)	S0889015