



AUTOMATIC IN-FLOOR CLEANING & CIRCULATING SYSTEM INSTALLATION MANUAL



U.S. Patent No.: 4,114,206 4,592,379 4,939,797 5,135,579 5,251,343 5,265,631 6,301,723 6,311,728
6,314,999 6,360,767 6,367,098 6,393,629 6,601,244 6,810,537 7,089,607 D,532,684 D,531,888
7,178,179 Other Patents Pending Canada patents 2,028,766

Notice to Installers:

Read and follow these instructions. Give these instructions to the facility owner. Follow all codes and regulations that apply to the design, installation and use of suction outlet fittings.

VAN0689 004-027-8720-00 REV040111



Rainbow Pool Products

PO Box 2388, Mansfield Qld 4122

Telephone STD 61-7-3849 5385

Facsimile STD 61-7-3849 5384

Email: info@rainbowpoolproducts.com.au

Web: www.rainbowpoolproducts.com.au

FORWARD

The Paramount VANTAGE IN-FLOOR CLEANING SYSTEM is the culmination of years of extensive testing and engineering which provides your customers with the most advanced and trouble-free system available. The information contained in this manual is intended to answer some of the most common questions associated with the installation of the System. We urge you to take time to review it thoroughly.

If you have any questions call Toll Free 1.800.621.5886 or visit www.1Paramount.com

IMPORTANT NOTICE

The Paramount In-Floor Systems are protected patented products and the "methods and installation" of said products are patented.

An installer of these products must be trained and licensed by Paramount. This manual and documents contained within have been copyrighted and any reproductions are illegal without the written permission of Paramount Pool and Spa Systems.



Paramount

Pool Life. Simplified.

TABLE OF CONTENTS

VANTAGE LAYOUT & DESIGN	2-4
DEBRIS DRAIN INSTALLATION	4
PRE PLUMBING/VANTAGE FLOOR AND STEP HEAD INSTALLATION	5-8
DEBRIS CANISTER INSTALLATION	9
NUMBERING THE WATER VALVE PORTS	10
LOCATION OF WATER VALVE & AND PIPE GRADE & SIZE	11
2" VALVE BASE PLUMBING GUIDE & GLUING INSTRUCTIONS	11-13
AUXILIARY EQUIPMENT CONNECTIONS	14
PUMP INSTALLATION	15
START-UP	16
WINTERIZATION	17-18
TROUBLE-SHOOTING	19-22
BILL OF MATERIALS	23-25

PLUMBING DIAGRAM

DRAWING

XXX

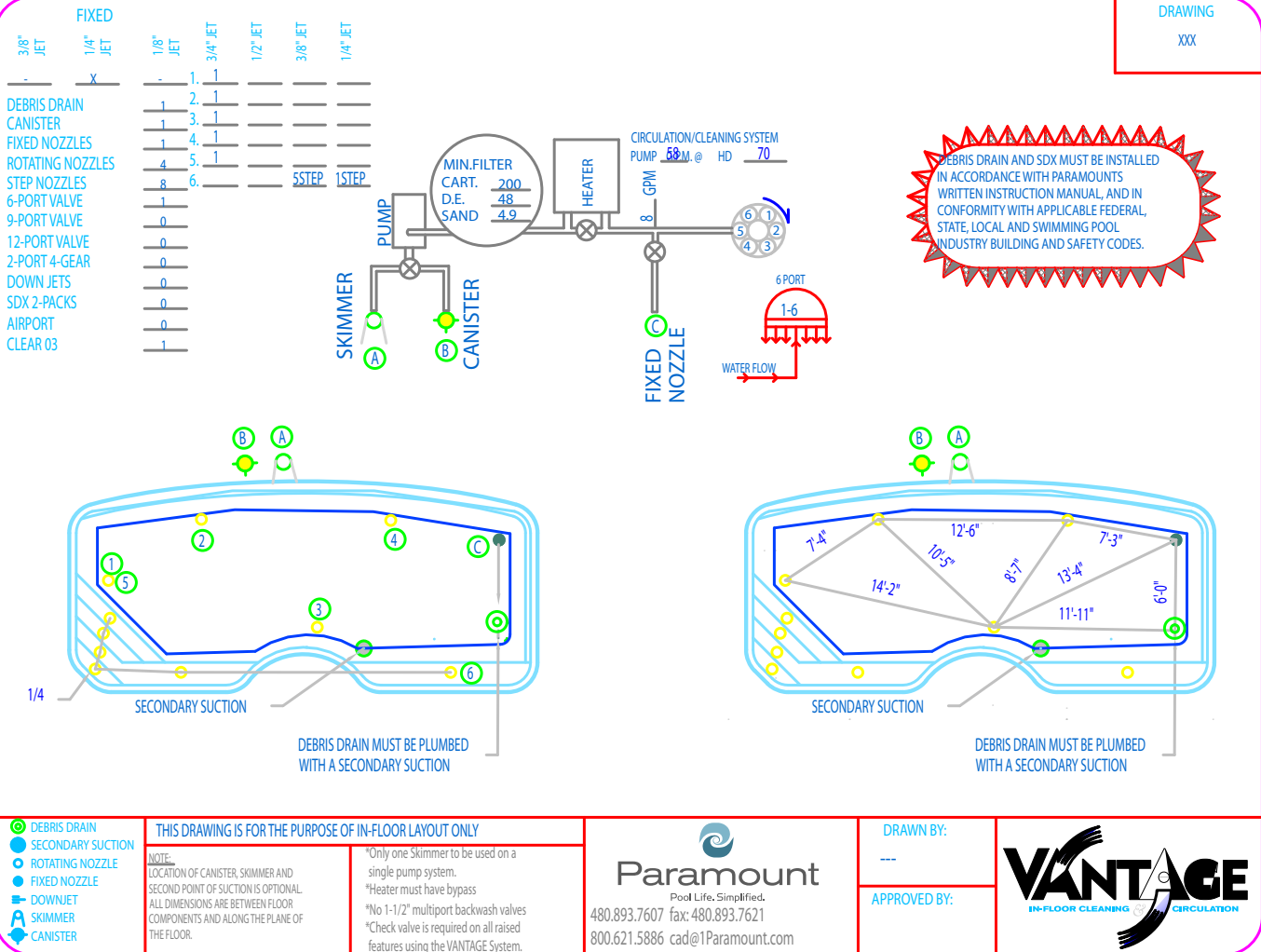

VANTAGE, VANTAGE PLUS & VANTAGE ULTIMATE:

The Vantage System for pre-formed composite pools is a specialized variation on the Paramount PCC 2000, which is the most advanced In-Floor Cleaning and Circulation system available for swimming pools in the world today.

The Vantage System offers several levels of cleaning, starting with basic floor circulation. Options are available to fully clean the floor, steps, and manage (water curtain) and contain (canister) leaf debris.

Dual Pump System

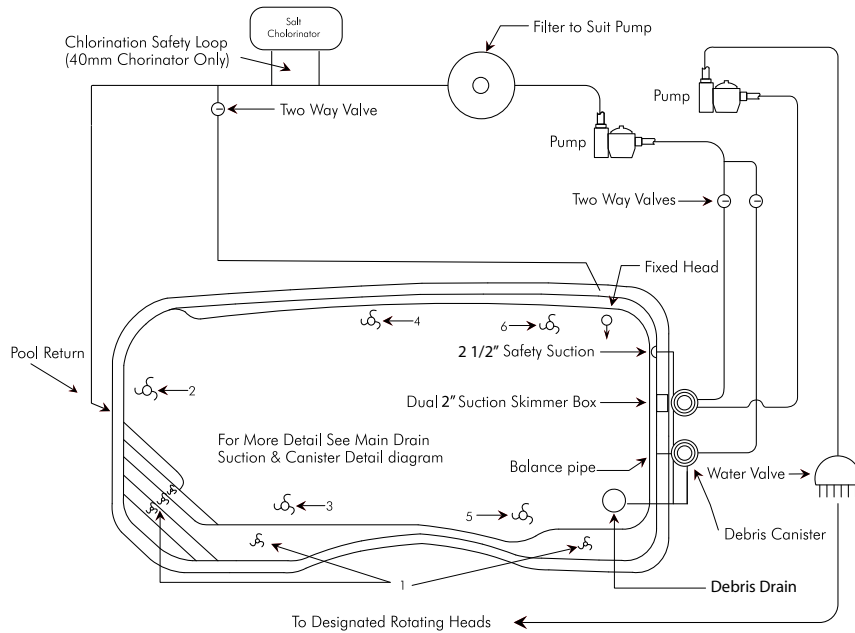

Single Pump System

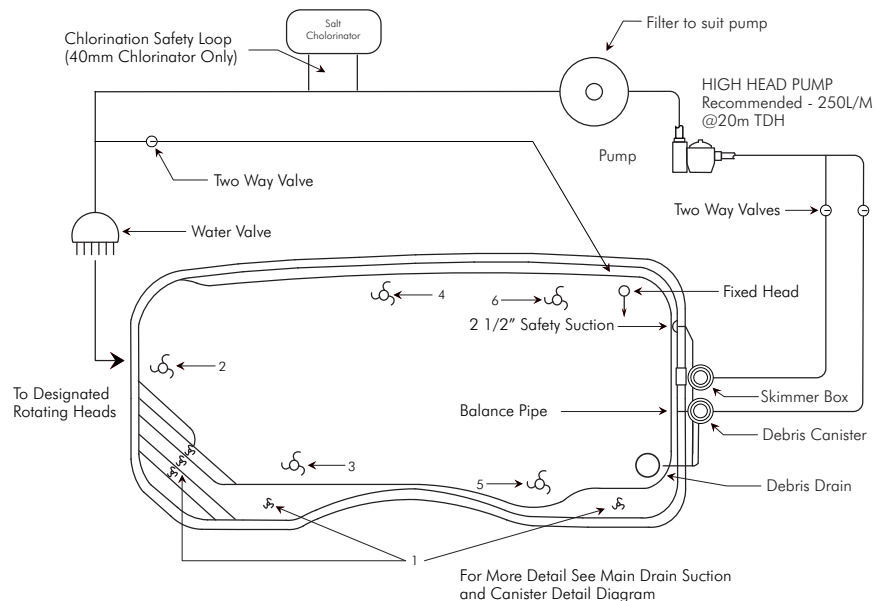

VANTAGE, VANTAGE PLUS & VANTAGE ULTIMATE:

Port Sequencing

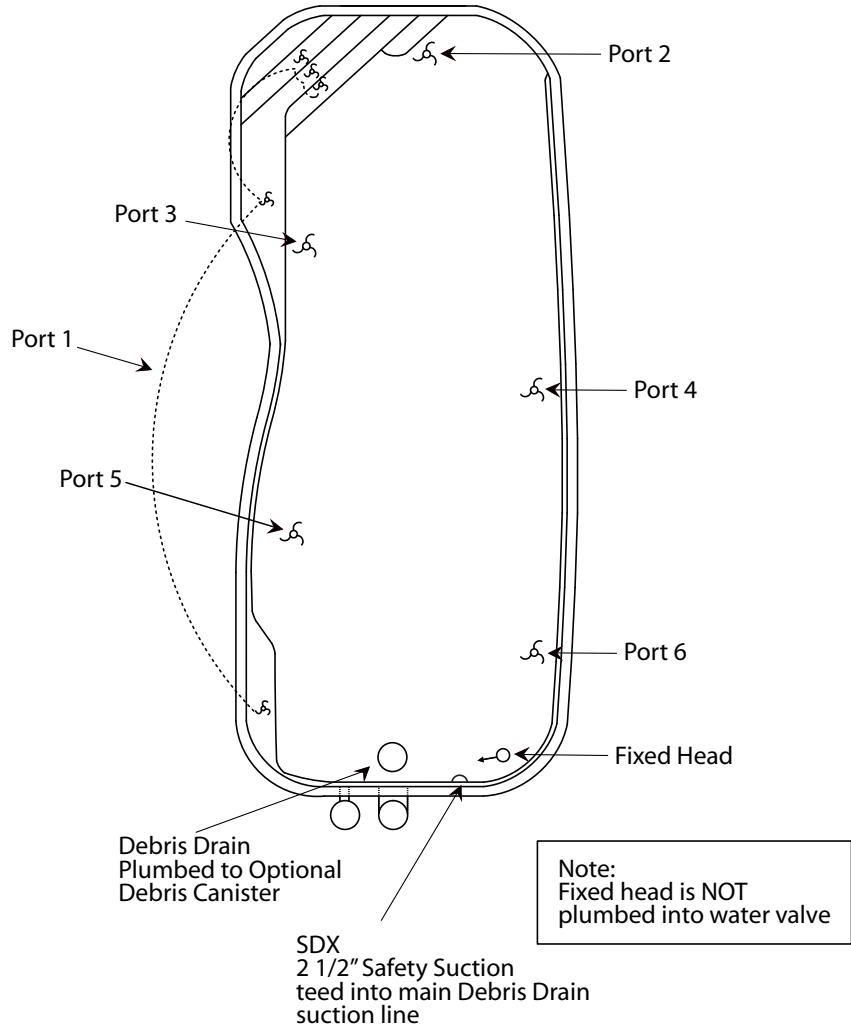

DEBRIS DRAIN INSTALLATION

POOL DRAIN SYSTEM

System Design:

NOTICE:

WARNING: The drain used must be installed in accordance with the manufacturers written instruction manual, and in conformity with applicable Federal, State, Local and Swimming pool industry building and safety codes.

If you use one of the Paramount 'Anti-Entrapment Debris Drains' consult the applicable manual for specific instruction on how to plumb.

MANUAL PART NUMBERS:

MDX-R3 Fiberglass: 004-027-8825-00

MDX² Fiberglass: 004-027-8791-00

VANTAGE INSTALLATION

BODY INSTALLATION TO SHELL BEFORE SETTING POOL

Floor Head Installation

Remove the red construction cap from the top of the black body socket.

FIG. 1

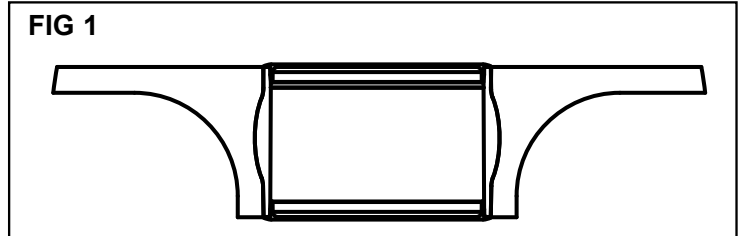

Attaching the colored trim ring.

Always install the trim ring first to ensure proper alignment of the nozzle to the pool floor.

FIG. 2

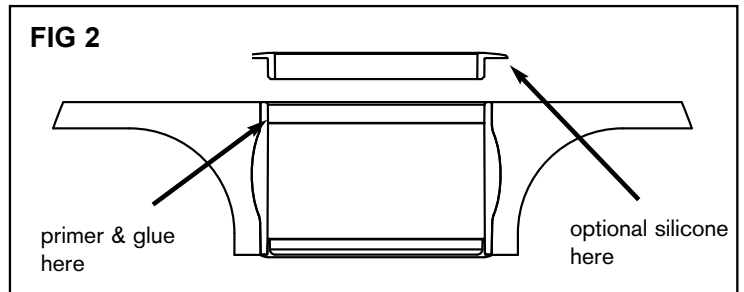

Primer the inside of the black body socket built into the pool. Use PVC glue to glue the flange of the trim ring (Fig 3) into the top of the black body socket on the finished side of the pool. Make sure the trim ring top is flush with the surface of the pool.

A small bead of silicone sealant may also be used on the top flange to seal the flange to the pool shell. This will prevent any weeping leaks between the shell and the body socket.

FIG. 3

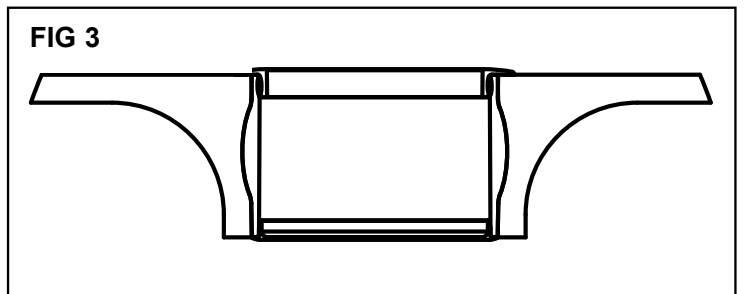

Remove the lower red safety cap if you have not already done so.

FIG. 4

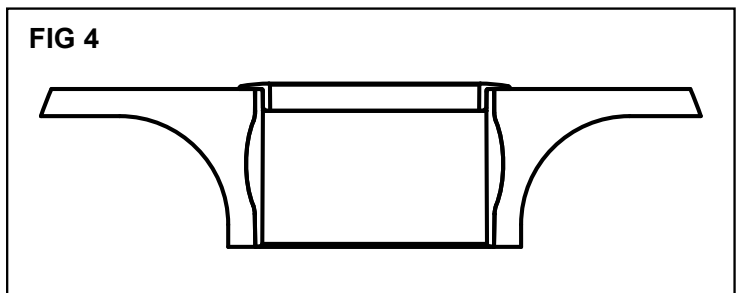

VANTAGE INSTALLATION

BODY INSTALLATION TO SHELL BEFORE SETTING POOL (continued)

Primer and glue (using a slow drying glue Weldon IPS 705 or 711) the flange on the bottom of the floor body supplied in the kit, **working glue into the recessed chamber on the outside of the flange** so there will be a glue joint on the outside of the flange and the inside of the recessed area. Then primer and glue the **outside and inside** of the 2 ½" side of the 2 ½" x 2" 90. Push the body and 90 together making sure that the top of the 90 bottoms out in the recess of the outside of the flange on the body.

FIG. 5

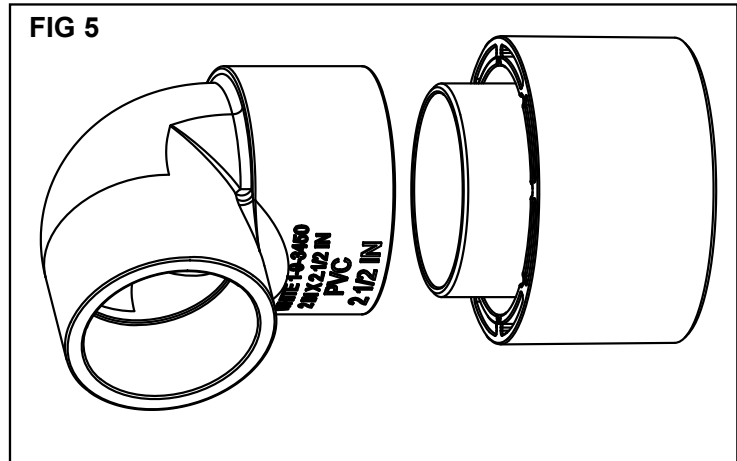
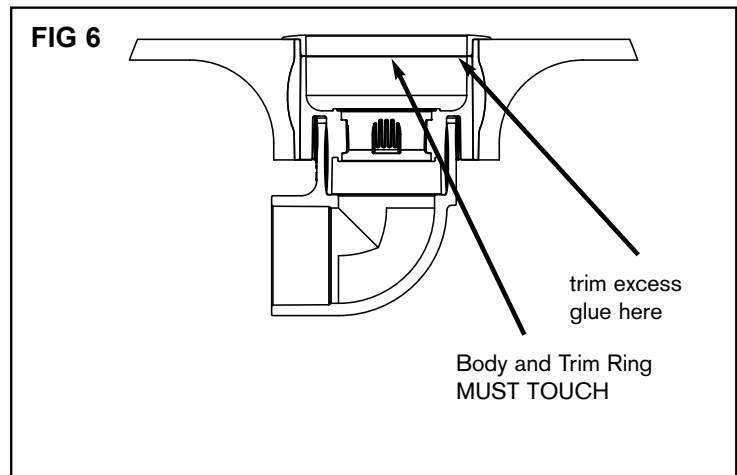

Fig 6 shows the glue joint of the 2 ½" side of the 90 and the flange and recessed area of the body.

WITH THE 2" OPENING OF THE 90 POINTING TO THE DIRECTION YOU WANT THE PLUMBING TO GO, primer and glue the inside of the black body socket and the outside of the body glued to the 90 and push it together **making sure that the body bottoms out on the colored trim ring**.

If excess glue squeezes out inside the body wipe away so not to interfere with nozzle installation.

FIG. 6



VANTAGE INSTALLATION

BODY INSTALLATION TO SHELL BEFORE SETTING POOL (continued)

FIG 7 shows a cross section of the floor nozzle in the Vantage body with the 2 ½" x 2" 90° ell glued into the body.

NOTE: VANTAGE FLOOR NOZZLES INSTALL COUNTER CLOCKWISE AND COME OUT CLOCKWISE.

FIG. 7

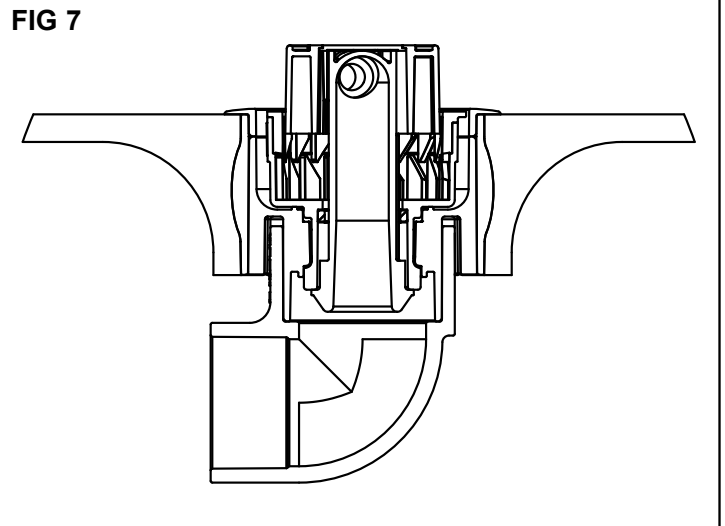

Vantage Step Nozzle and Body

Install the step body just like the floor body except they step body is smaller and the 90° ell is 2". A 2" coupler may be used in place of the 90° ell

NOTE: THE STEP NOZZLE CAP SHOULD BE PLACED ON THE NOZZLE SHAFT AND THE BOTTOM OF THE NOZZLE SET ON A HARD SURFACE. WITH THE PALM OF YOUR HAND STRIKE THE TOP OF THE CAP TO SNAP IT IN PLACE. VANTAGE STEP NOZZLES INSTALL IN THE REVERSE OF THE FLOOR NOZZLES. TO INSERT, TURN CLOCKWISE AND TO REMOVE TURN COUNTER CLOCKWISE.

FIG. 8

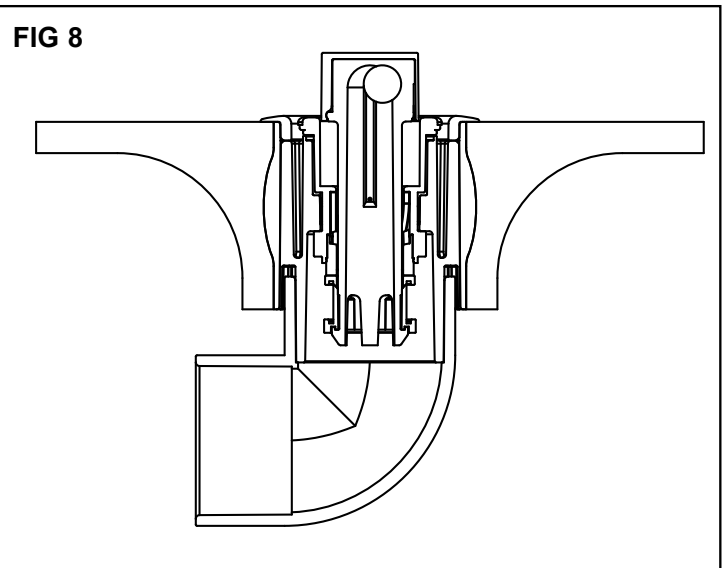

INSTALLATION

PRE-PLUMB STEP AND FLOOR NOZZLES UP WALL BEFORE SETTING POOL



FOOTNOTES ON STEP MANIFOLD PLUMBING

When plumbing step manifolds that include Bench nozzles, follow the procedure pictured including the bench nozzles in the manifold. Place the 2" T on the longest section of step Manifold for best equalization.

STEP MANIFOLD DETAIL – TYPICAL OF ALL STEP INSTALLATIONS

Using 2" PVC, construct the manifold in a manor that best suits the situation.



Plumbing the Vantage system while on the delivery trailer (if the driver can wait) or on the ground before setting, makes the job easier. (if you must set your pool on the ground, be sure to place support blocks under it, do not allow the pool to rest on Vantage ports.)

All plumbing is 2" ridgid schedule 40 PVC. Make sure and keep all plumbing as close to the vessel as possible for easy placement in your excavation.

The Vantage system is a pressure side cleaner, be sure to make solid glue joints.

Extend each port riser to the under side of the pool lip, once you have set the pool you can cut your pipe to match your plumbing ditch.

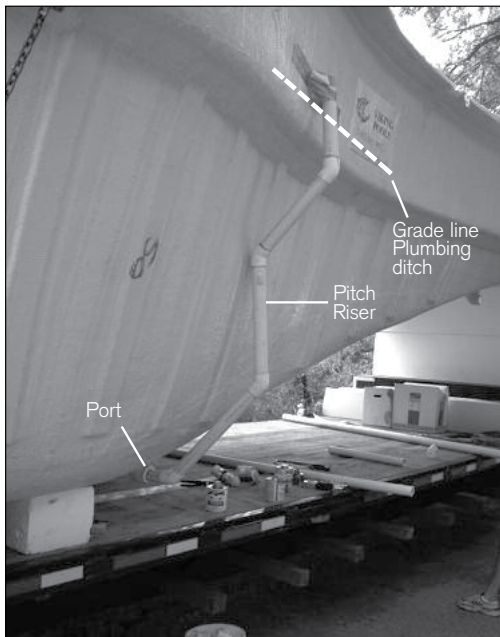

INSTALLATION

Debris Canister:

The Debris Canister must be set in the pool deck, as close to the pool as practical and be fitted with an unimpeded 1-1/2" Balance Pipe (also called an "Equalizer Pipe") between the Pool and the Canister. This is to permit pool water to flood the lid of the Canister. Seal with a plug all unused outlets in the canister.

SET CANISTER AT SAME LEVEL AS SKIMMER

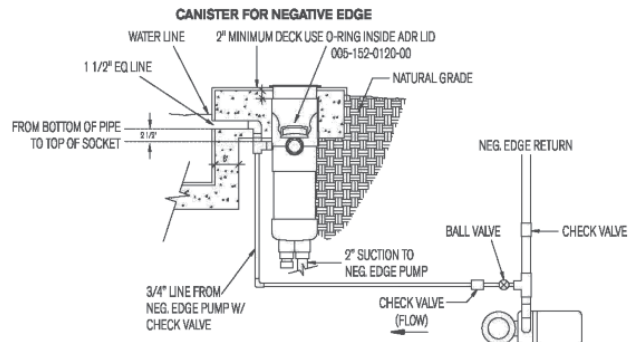
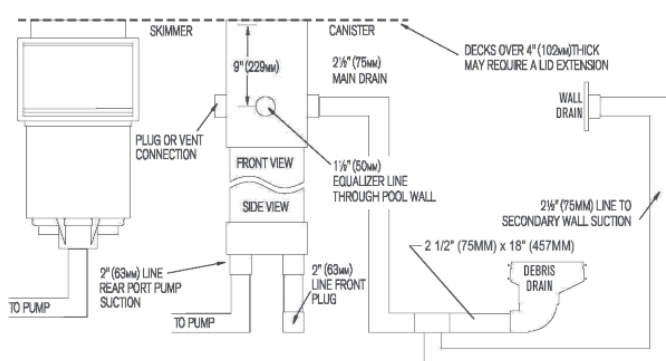

Coloque la canastilla al mismo nivel que la espumadera

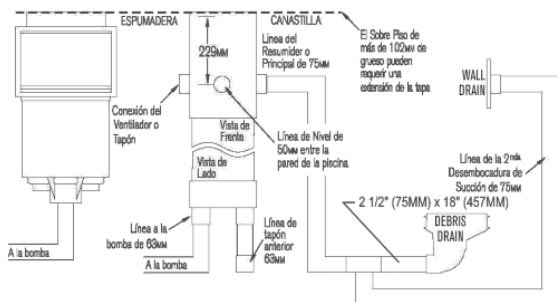

Régler la boîte au même niveau de l'écumoire

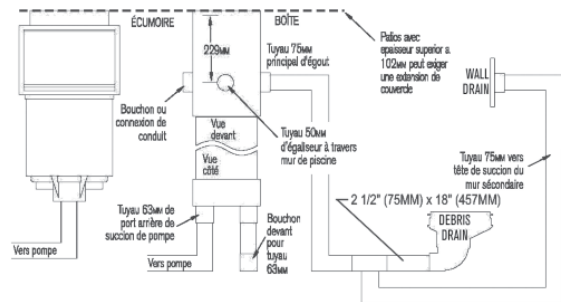

REV 12/08
 Powered by
Paramount
 Pool Life. Simplified.

295E. Corporate Place, Suite 100 · Chandler, Arizona 85225 · 800.621.5888 · Fax: 480.893.7621 · Paramount@1Paramount.com · www.1Paramount.com

001-025-8222-00

INSTALLATION

Pipe Grade & Size:

Use 2" sch40 pipe throughout the Vantage system plumbing including connections to the Water Valve. It is permissible to use 1-1/2" sch40 pipe to join the step and seat heads together. The pipe run from the Water Valve to the first Tee must be 2". Try to minimize pipe runs and use of 90° elbows. Excess pipe and 90° elbows cause a drop in efficiency. Each 90° elbow is equal to the pressure drop of about 3 feet of pipe. Using 2 -45° elbows in place of a 90° elbow doesn't really help on the pressure side as 2-45° elbows causes slightly more pressure drop than 90° elbow.

Location of the Water Valve:

Position the Water Valve as close to the pool as practical. This has several benefits:

It reduces the cost of installation, in terms of both time and materials, as only one pipe covers the greater distance from the equipment to the valve and six the lesser distance from the Water Valve to the pool.

It allows the owner (as well as the Pool Technician) to adjust the Pause/Run Control with the pool in view.

Numbering the Water Valve Ports:

The Water Valve ports are number 1 to 6 clockwise when looking down at the Water Valve Base. Start the numbering at any port. Plumbing the valve out of sequence may cause a drop in the system's overall efficiency.

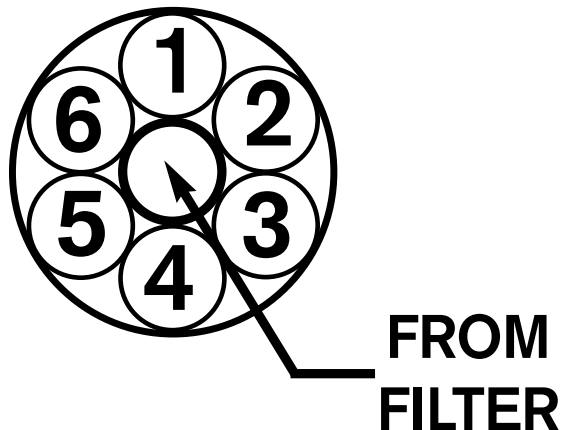

INSTALLATION

2" VALVE BASE PLUMBING GUIDE

NOTICE: All pipe fittings MUST be staggered. (See pictures on page 21)

All plumbing should be 2".

The water valve is normally set 6" above water level in a convenient location poolside. This results in dramatic reduction in plumbing runs and increased cost savings.

The center port of the bottom housing is the inlet to the valve. Cut all pipes square, this allows maximum gluing surface to the bottom housing. USE PVC PRIMER AND GLUE ON BOTTOM HOUSING AND ON PVC PIPES. Prime bottom valve housing two times and prime the pipe once.

Glue pipe all the way into the stop and allow at least 24 hours drying time before pressure test. To prevent glue damage to internal ribs always glue with the valve right side up.

If not all six (6) ports are required, use one of the ports twice to feed one return line. The common ports should not be plumbed next to each other, always skip a port when double firing. The pipes from the water valve should be connected together underground.

VALVE FOR 4-PORT SYSTEM

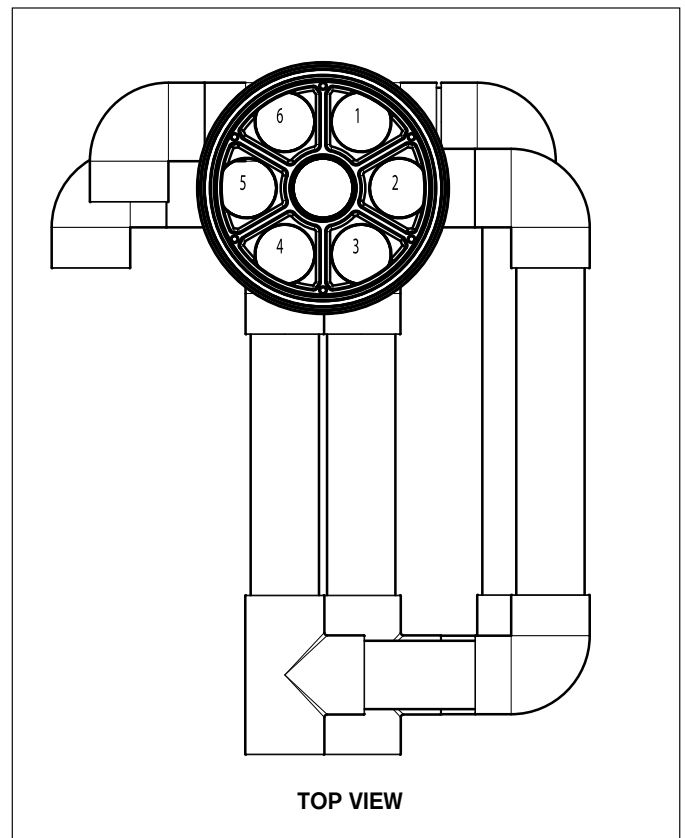
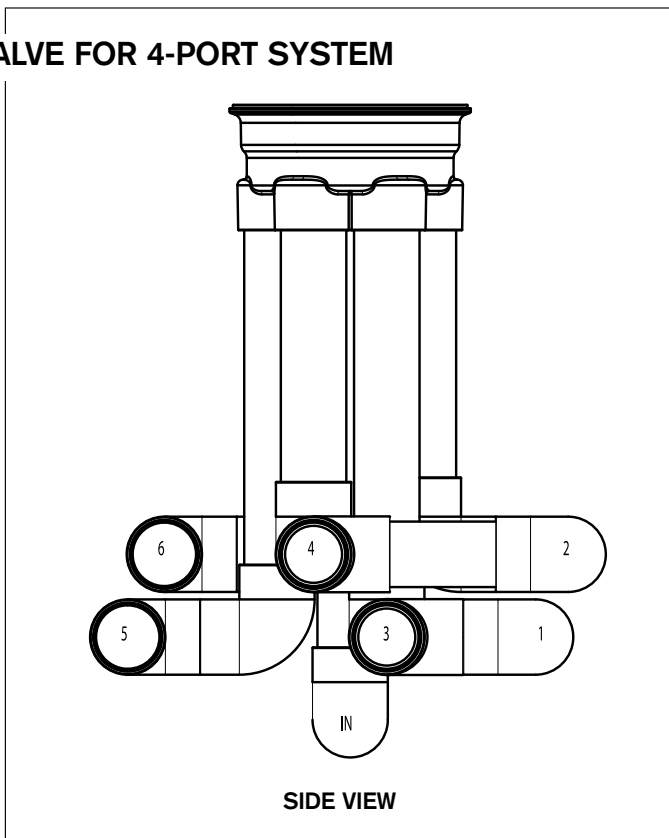

FOR A 4-PORT SYSTEM, ZONES 2 AND 4 ARE TIED TOGETHER AND ZONES 1 AND 3 ARE TIED TOGETHER

INSTALLATION

VALVE FOR 5-PORT SYSTEM

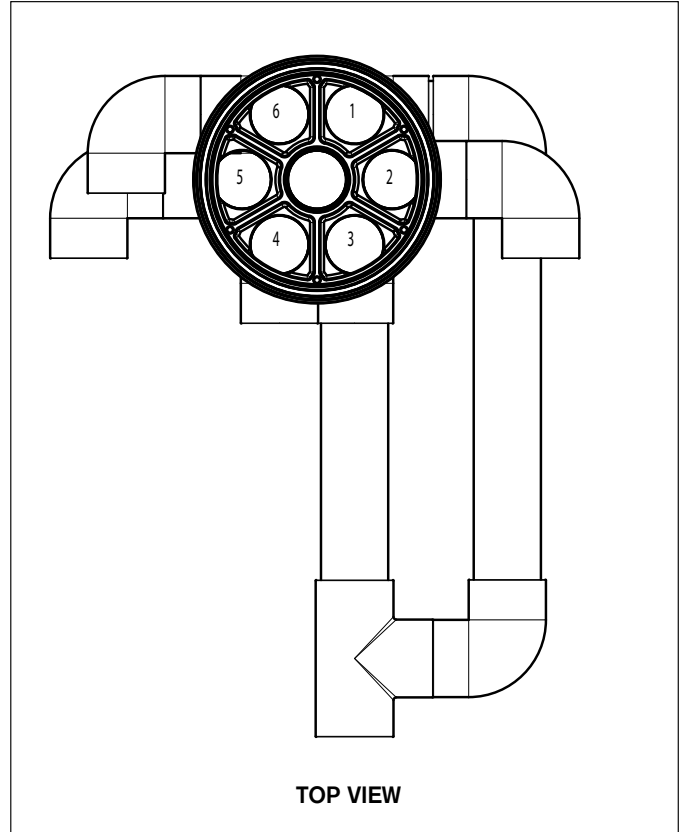
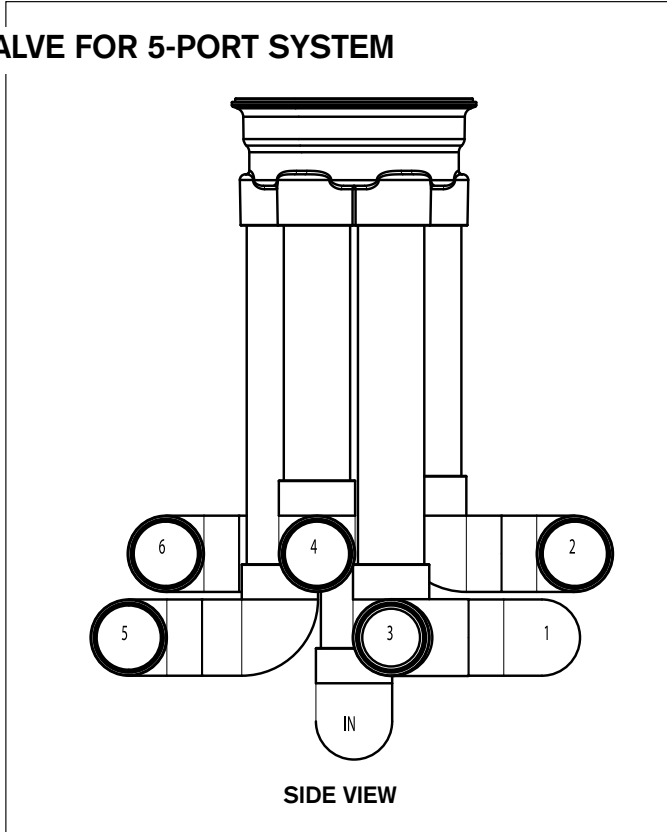

FOR A 5-PORT SYSTEM, ZONES 1 AND 3 ARE TIED TOGETHER

Gluing Instructions

1. Remove Clamp
2. Lift off dome (save O-ring)
3. Remove pressure gauge and T-handle from inside valve housing assembly.
4. Pipes and valve base should be treated with primer.
5. Make sure pipes are glued all the way into the stop. Be careful not to allow glue to run into module area.*
6. The center port is the inlet to the valve and should be approximately 3" longer than the perimeter pipes.
7. Allow 24 hour before pressure testing.
8. Reposition o-ring in groove in the valve base.
9. Replace dome and V-Clamp and tighten until snug.
10. Thread the pressure gauge to the top of the dome. DO NOT USE TEFLON TAPE
11. Pressurize with pool plumbing (do not exceed 35 psi.)
12. Store the module assembly in a safe place and install after the pool has been started up.

* Pipes should be a minimum of 12" in length and should insure the valve be at least 6" above water level.

INSTALLATION

Plumbing (Equipment) 2" VALVE BASE PLUMBING GUIDE

NOTICE: All pipe fittings MUST be staggered.

PARTS NEEDED FOR ASSEMBLY OPTION ONE

- (3) 2"X12" PVC PIPE (port 2,4,6)
- (3) 2"X15" PVC PIPE (port 1,3,5)
- (1) 2"X18" PVC PIPE (port inlet)
- (4) 2"X2 1/4" PVC PIPE (port 1,2,5,6)
- (11) 2" SLIP 90° ELBOWS
- Optional: replace (4) 90° elbows and (4) 2"x2 1/4" pipes with (4) spigot 90° elbows
- Set in trench 15" deep X 19" wide

NOTE: Height of riser pipes may be adjusted as long as the 3" height differential between fittings is maintained.

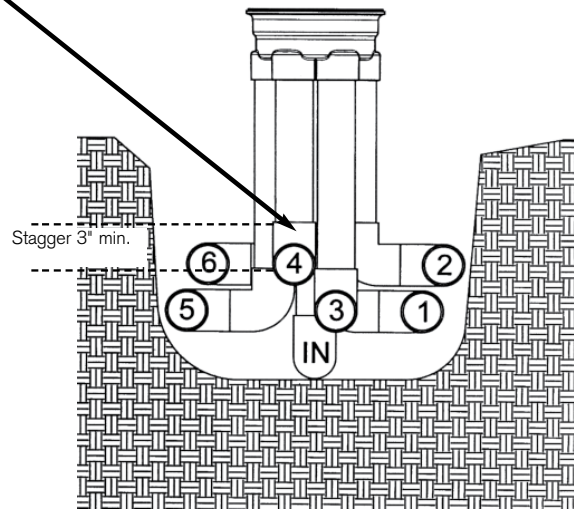

AUXILIARY EQUIPMENT CONNECTIONS

Suction from Pool:

For safety and to fine tune the system, the pump driving the Water Valve must have suction lines from both the Skimmer and the Debris canister (&/or Active Drain). Additionally, these suction lines must each have a Two-Way valve in-line or a Three-Way Valve to permit correct adjustment to the suction flow.

Ancillary In-Line Equipment:

Where there is ancillary equipment (such as heaters and sanitizers) fitted in-line between the filter (or dedicated pump) and the Water Valve, they MUST be fitted with a bypass incorporating a Two-Way Valve to permit some of the water to bypass the ancillary item. This reduces the loss of pressure caused by the ancillary equipment AND extend its life by reducing erosion in that equipment due to the high pressure flow rates required by the Vantage system.

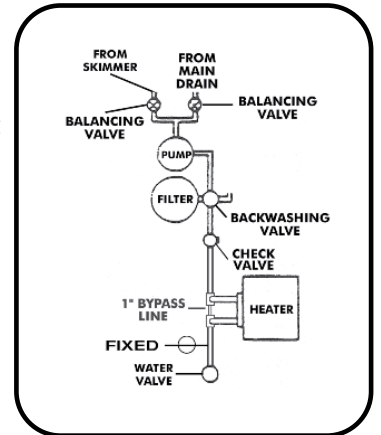

Solar systems should NOT be plumbed in-line without a dedicated solar pump AND the approval of the Solar Supplier that the Solar system supplied will accommodate the pressures involved. It is usually preferable to plumb the Solar on its own dedicated suction & return lines.

Ozone generators installed in-line MUST NOT be set so as to permit visible air bubbles to exit the Vantage nozzles. In addition, the bulk of the water going to the Water Valve MUST bypass the Ozone Venturi injector which is a prime pressure loss point. The Ozone generator supplier should be consulted to offer advice as to whether the Ozone generator contemplated can operate satisfactorily under these conditions.

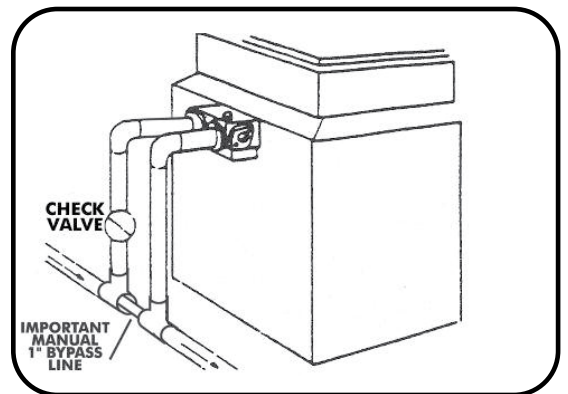

Pump Connections:

The suction pipe entering the front of the hair & lint pot on a pump MUST have at least 12" of straight horizontal pipe before the 90° elbow. Having an elbow closer to the pump suction point causes turbulence and cavitation. When this occurs the pump runs at a level far below its rated performance and in the case of a Vantage system, prevents it from working to its optimum performance level.

One & Two Pump Systems:

Vantage can work equally well as a one pump or two pump system. The critical thing is that the Water Valve receives sufficient water volume at an adequate pressure. The design figure is 50 GPM at 20-25 psi (measured at the Water Valve). Selection of an adequate pump and filter is important. Take the time to check the pumps flow curve and select a filter greater than the minimum listed on the design sheet.

PUMP INSTALLATION

One Pump Systems:

The pump must be a high head pump capable of 60 gpm at 70 ft. of head and the filter should be a minimum of a 4.9 sand filter with a two inch valve, 36 sq. ft. DE filter with a two inch valve, or a 200 sq. ft. cartage filter. This will be sufficient to give the required 50 gpm flow to the cleaning system and allow 10 gpm for the possible fixed nozzle. Any additional water needed for spa spill ways, water falls or other water features must be factored in to both pump and filter sizing.

If a fixed nozzle is required on the pool then it is not plumbed thru the water valve. It will need its own return line plumbed in before the water valve. If the pool is of a size that it does not need to use all six ports of the water valve then the extra port may be plumbed to returns or doubled up on one of the other in-floor circuits.

NOTE: ALL SIX PORTS ON THE VALVE MUST BE PLUMBED TO HEADS OR RETURNS TO AVOID DEAD HEADING THE PUMP.

Single Pump System

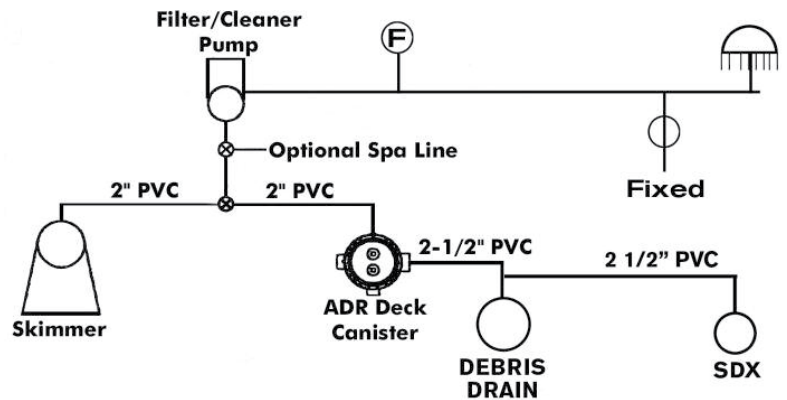

Two Pump Systems:

The selection of the filter and its pump is somewhat simpler as it is not driving the water valve and cleaning heads. The filter pump will draw from the active main drain (via the optional debris canister is used) AND MUST HAVE A LINE FROM THE SKIMMER AS WELL. Both suction lines need a separate line and valve so they can be adjusted. This is necessary so the pool has a way to add DE on a DE filter and to regulate the skimmer suction so the proper active main drain flow can be obtained.

The filter pump must have return fittings in the pool to return the filtered water to the pool and if the in-floor system includes a fixed nozzle(s) then it will also need a separate valve on the return line going to the fixed nozzle(s). Many Vantage designs do not have fixed nozzles. Use your design plan from Paramount to determine whether or not you will have a fixed nozzle(s). If you did not get a head layout plan call Paramount at 800-621-5886 with the size and type of pool you have.

The Booster pump for the cleaning system will pull from the second port of the skimmer or from a second skimmer. It must be a high head pump capable of 50 gpm at 60 ft. of head.

Dual Pump System

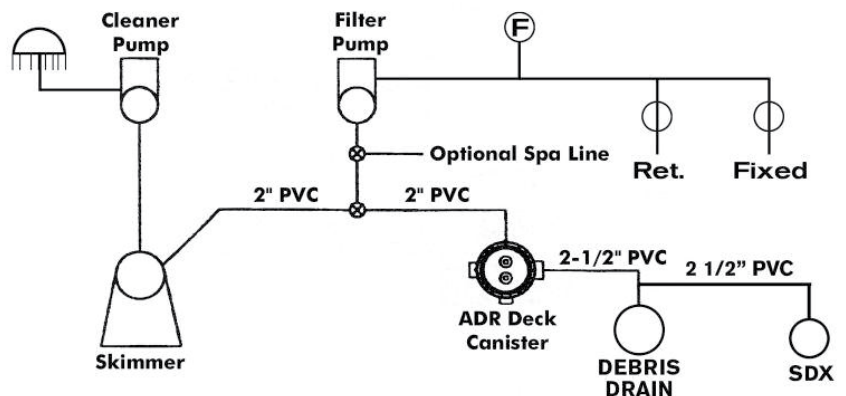

START UP

General Observations Concerning Water Valve and Nozzles:

1. As a rule, do not install the module until after filling the pool and running the pump for at least ten minutes. After installing the module run the valve for several cycles to clear the plumbing runs to the pool of debris. Install the nozzles from poolside with the Nozzle installation tool. If the line has more than one nozzle, install one and let the line cycle again to clear the transfer line between the nozzles.
2. NEVER use any form of grease, lubricant or sealing compound in the Water Valve, its module, "O" rings etc. This will only trap debris and accelerate wear and failure of the module.
3. When putting the lid and clamp ring on a Water Valve, ensure first that the "O" ring groove is clean and free from grit and then properly seat the "O" ring. Next, properly seat the lid so that it spins smoothly backwards and forwards. Fit the Clamp ring and tighten the nut by hand. Tap the clamp around its perimeter with a screwdriver handle or similar then tighten the nut again by hand. Repeat this procedure until it is no longer possible to tighten any further by hand. Then tighten the nut with a 5/16" wrench. Stop tightening if it squeaks. If after starting the pool pump, the Water Valve leaks at the clamp DO NOT continue to tighten any further. Remove Water Valve lid and repeat the entire procedure.

General Observations Concerning Nozzle Jet Sizes:

Once the pool is running, turn off pump and install module in water valve. Turn on pump and blow out all lines. If more than one body is on a line, you must plug off all but one body on the line at a time. Once it is cleared out, do the other bodies on the line one by one.

NOTE: Use the pause control on the water valve to lock the valve on that circuit until all the bodies have been blown clean. Then install the nozzles.

The step and bench nozzles will be set up to flow 50 to 60 GPM. Top steps will normally be a 5 GPM 1/4" cap which cleans a 3' radius. Other steps will normally be a 3/8" 10 GPM cap which cleans a 5' radius. The 5/8" cap is for very long benches and cleans a 7' radius at 20 GPM. **To install cap, place on top of nozzle, place bottom of nozzle on a hard surface, and hit down on the cap the the palm of your hand.**

With respect to the Rotating Floor Nozzles, where there is one Nozzle on a port, it MUST be a 3/4" jet. If there are two Rotating Floor Nozzles on a single port they MUST both be 1/2" jets.

Fixed Nozzles require 3/8" jets and are plumbed before the water valve on a single-pump system, or on **a separate line** from the return on a two-pump system.

A two pump booster system must have pool returns separate from the cleaning system.

NOTE: Step Nozzles (small) insert clockwise
Floor and Fixed Nozzles (large) install counter clockwise

WINTERIZING INSTRUCTIONS

Winterizing a Paramount Pool & Spa Systems in-floor pool is the same as any pool with a main drain; it just has a few more lines to winterize. These procedures are to be used in addition to standard winterization methods normally used in your area.

To Do List:

- Store the Paramount valve module, canister inner lid and basket in a safe, dry place.
- Remove and store any "down-jets" located above the freeze line.
- Blowout and airlock all pool lines.
- Remove all water from the canister and replace with swimming pool anti-freeze and an empty jug, the same way you winterize skimmers.

The following steps are procedures recommended for proper winterization of the Paramount In-Floor Cleaning Systems. These procedures do not replace normal winterization procedures but are instead in addition to them.

FOR DRAIN WINTERIZATION INSTRUCTIONS CONSULT MANUFACTURER'S INSTRUCTIONS FOR THAT DRAIN.

PARAMOUNT CANISTER WINTERIZATION

1. Remove outer lid, inner lid and basket, clean and dry off, and store in same area as modules
2. Install and secure regular winterization plug in equalizer line of canister to pool at poolside.
3. Install and secure Schrader plug or blow out plug from canister to main drain. Blow out and obtain air lock as previously described, if skimmer is tied into canister, repeat procedure to skimmer.
4. Bottom port of canister to pump may require an extended pipe for ease of blowing out. Install and blow out line from canister to pump. Install and secure plug in pump. Using a wet/dry shop vac, remove all water from within canister components.
5. Extension pipe can be removed and replaced with plug or Gizmo type container if Gizmo not used. Be sure to install device to absorb ice expansion in canister area. Failure to do this may result in potential ice freeze damage to canister.

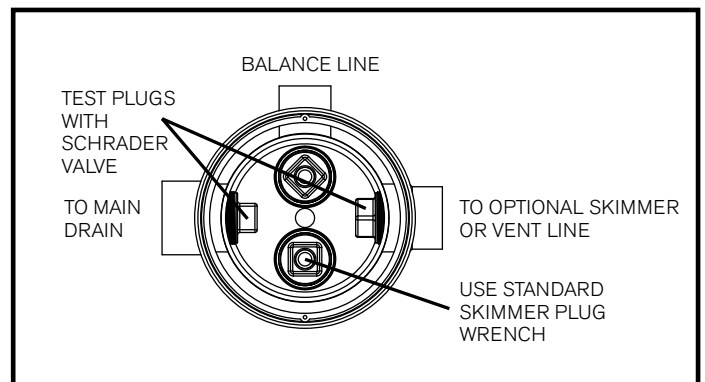

Winterization anti-freeze is to be used as necessary or when required.

Additional questions should be forwarded to Paramount's corporate office at 1.800.621.5886.

WINTERIZING INSTRUCTIONS (Cont.)

WATER VALVE

NOTE: 1 1/2 and 2 inch test plugs with Schrader valves are available through your pool store or local wholesaler. The Special trapezoid plug with Schrader valve is available through Paramount Part number 004-302-1670-00. These are the test plugs referred to in Step #6 and Figures 4 and 5 (and only fit 2" valve)

1. Turn off and drain out all pool equipment.
2. Remove valve lid or lids from valve(s). (See Fig. 1)
3. Remove module(s) from valve housing(s). Store module in dry clean area out of the winter elements for winter until reinstallation in spring. (See Fig. 2)
4. Remove any down jet returns in pool (threaded or slip) including down jet body for a secure fit of winterizing plug. Store with module(s). (See Fig. 3)
5. From valves to pool, place a Schrader plug or blow out plug as recommended
6. Install and secure Schrader or blow out plugs in all parts of valve(s) Fig 4 - Step #6 (except center feed port of second and multiple valves when multiple valves are being used). (See Fig. 4)
7. Proceed to blow out lines through Schrader or blow out plugs to pool.
8. While blowing out the in-floor nozzles, once a good amount of air has come through the nozzle, you have accomplished an air lock. (This procedure is similar to obtaining an air lock when blowing out the bottom drain in the pool.)
9. Blow out center port of the valve with the module with tubes on top back to filter equipment and plug. (See Fig. 4) Step #9
10. While blowing out the down jets and while air is escaping through the in-wall hole, install and secure a regular winterizing plug.
11. Repeat until all ports are blown out. (See Fig. 4) Step #11
12. In cases where multiple valves are in use, blow out the feeder port of the first valve into the center port of the second or multiple valve(s), install, and secure plug.
13. When necessary, pool winter anti-freeze solution should be poured into each line.
14. Valve housing(s) should be wiped clean and dry of water, reinstall top lid and secure. (See Fig. 1)



Fig. 1



Fig. 2



Fig. 3

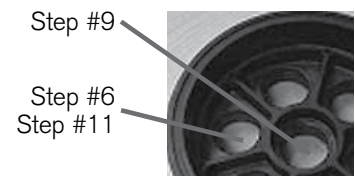

Fig. 4



Fig. 5

2" Base



Fig. 6

TROUBLE SHOOTING

Typical Mistakes Made During Installation and Orientation:

The following are mistakes occasionally occur. Fortunately, they are rare when well-trained, experienced, conscientious installers have carried out the installation!

- Allowing dirt and debris to get into the pipe work during construction
- Use of 1-1/2" pipe instead of 2" pipe
- Water Valve set too far from, or out of sight of the pool
- Water Valve set unnecessarily too high or low with respect to pool level
- Two Way valves not used where Water Valve is below water level
- Grease or sealing compound used in Water Valve
- Water Valve closely surrounded by concrete or pavers (can't remove lid)
- Water Valve plumbed with the wrong firing order
- Drips of glue on the interior ribs of the Water Valve Shell
- Valves needed for tuning not installed at all (especially for fixed nozzles & down jets)
- Unnecessarily long runs of pipe with too small of pipe (loss of pressure)
- Unnecessarily complicated & convoluted pipe work in equipment area, with too many elbows
- Lack of by-pass (and two way valves) around Ancillary equipment
- Undersized pumps and/or filters
- Improperly glued fitting
- Incorrect Nozzle sizes installed
- Check valves not used where raised spa is being cleaned as well
- Lack of labeling on pipes and valves

TROUBLE SHOOTING

DIRTY SPOTS IN POOL:

Check that there is sufficient pressure at the Water Valve (20-25 psi). Note that the pressure at the valve not the filter is important here! If not then the cause of the low pressure must be established first. Possible causes of the low pressure include:

- Incorrect filter and/or pump
- Dirty filter, skimmer, pump basket or debris canister
- Blocked pipes or nozzles (could be on either the Suction side or the Pressure side of the pump)
- Lack of external by-pass lines fitted with a Two Way valve around Ancillary equipment
- Incorrectly adjusted Two Way valves starving the Water Valve - often adjusted incorrectly by owner or untrained pool service technicians
- 1-1/2" pipe work or excessive pipe runs or elbows
- Pump impeller problem
- Elbow too close to the suction inlet of the pump
- Problem with Multiport Valve on filter
- Leaking filter or pump
- Air in lines - check pump, Ozone Generator, Solar system etc- NOTE THAT IF THE WATER VALVE IS LEAKING, IT CAN ONLY LOSE WATER, IT CANNOT SUCK AIR!
- Lubricant or sealing compound used in Water Valve causing bypass on multiple ports of the valve

Steps To Cure Problems With Cleaning Performance:

- Ensure that the system wasn't intended to be a circulation system only (i.e. a basic Vantage system) - it may be actually cleaning at a degree equal to, or better than expectations!
- Check that the system is being run for a sufficient time each day to deal with the debris influx (type and quantity)
- Check that the Debris type is capable of being cleaned by the system
- Clean the filter
- Clean all baskets - skimmer, debris canister, pump
- Check that all ancillary valves are adjusted correctly
- Check for correct nozzle jet size
- Check that Fixed Nozzle is set correctly

TROUBLE SHOOTING

PRESSURE INCREASE AT FILTER:

- Clean the filter
- Clean all baskets - skimmer, debris canister, pump
- Check all ancillary valves are adjusted correctly

NOZZLE POPS UP BUT DOES NOT ROTATE:

- Push the nozzle up and down (with water pressure directed to that nozzle) to dislodge any debris
- If necessary remove the nozzle, dismantle and clean it. Clear the pipe by running the system on Pause on that line before reinstalling the nozzle

VALVE CYCLES BUT NOZZLES REMAIN UP:

- You can determine whether the module is at fault by removing and rinsing it then replacing it in a new position. If the problem shifts to a different nozzle, then it is probably the module. If the problem stays at the same nozzle then the problem is probably at the nozzle.
- Check for debris in the nozzle
- Check for (and clean out) glue or debris in the Water Valve base - particularly on the ribs or in the locating holes
- Check for debris lodged anywhere in the module
- If necessary replace module (defective modules must be returned to Distributor for Warranty Credit)

WATER VALVE DOES NOT CYCLE:

- Check Run/Pause switch is on Run
- Remove and clean module to ensure it is free of debris. Check that the Turbine shaft can spin freely and that the gears are meshing properly. If necessary, replace module.

NOZZLE WILL NOT POP UP:

- Check for clogged pipe or for debris in nozzle
- Check Water Valve is rotating

TROUBLE SHOOTING

LEAKING WATER VALVE:

- Lid incorrectly fitted - remove, clean thoroughly and replace correctly.
- Leaking Run/Pause control - generally only requires tightening, occasionally needs new seal.
- Damaged "O" ring (very rare) - remove and replace.
- Body Deformed or cracked (generally due to being set in concrete or pavers) - Major task unfortunately, original cause must be identified and not repeated when the body is replaced.
- Lid Cracked - probably caused by either the Pressure Gauge having been over tightened or the Clamp ring being installed incorrectly - remove and replace.
- Leaking Pressure Gauge - remove and seal with pipe joint stick (DO NOT USE TEFLON TAPE), or replace if necessary - do not over tighten!

WATER OR RUST IN VALVE PRESSURE GAUGE:

- A common occurrence with all pressure gauges and is not a problem unless the gauge has ceased operating

WHAT VANTAGE CAN & CANNOT DO:

When selling or servicing the Vantage system, it is vital that everybody involved ensures that the Owner is left with a clear understanding of what the system can and cannot do. In this way, you have happy, satisfied customer and the referrals that come as a result!

Vantage CAN dramatically reduce the running costs for sanitizing and heating a pool. It CAN eliminate dead spots and temperature layering and allow the owner to enjoy an extended swimming season. It CAN remove in excess of 99% of typical pool debris (depending on the version of Vantage selected) and reduce the pool owner's pool maintenance time to around 10-20 minutes of work per week in most situations. All of this presupposes that the Vantage system is set up properly and run for a time each day that is sufficient to deal with the type and quantity of debris that is entering the pool.

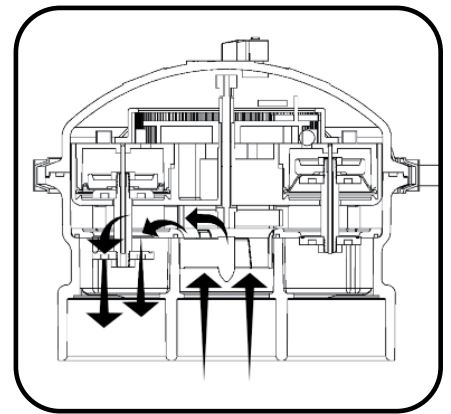

BILL OF MATERIALS

Part Number Diagrams

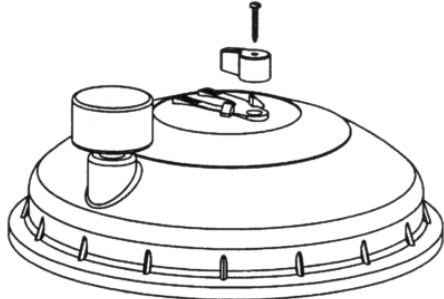

Top Dome Complete: 005-302-4300-03
(Includes: Top, Gauge & Pause Assembly)

Pause Assembly: 005-302-3502-00
(Includes: Screw, Knob, O-Ring & Pawl)

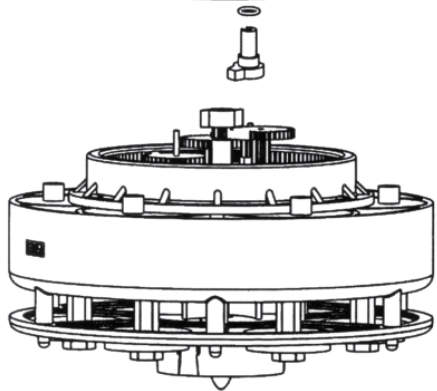

6 Port
Module Complete: 004-302-4408-00

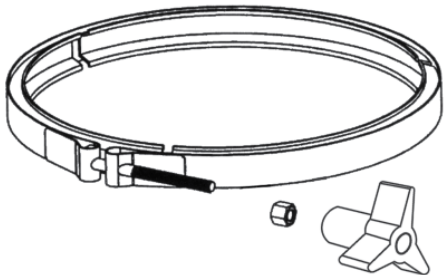

Band Clamp Complete: 005-302-3570-00
(Includes: Clamp, Nut, & Knob)

Band Clamp Nut Only: 005-302-0640-00
Band Clamp Knob Only: 005-302-3600-00



Valve O-Ring Only: 005-302-0100-00

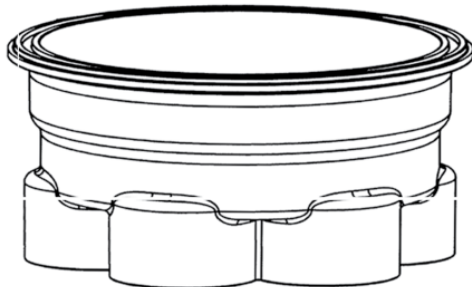

6 Port Base 2"
005-302-4032-03

6 Port Base 1½"
005-302-4030-03

BILL OF MATERIALS

ITEM	PART NO.	DESCRIPTION
*1	N/A	Vantage Escutcheon
*2	N/A	Vantage Retainer closure
*3	N/A	Vantage Main retainer CCH
*4	N/A	Vantage Nozzle stem
*5	N/A	Vantage Dowel Pin
6	005-602-0142-00	Vantage Nozzle O-ring 2-138 silicone (4 pcs)
*7	N/A	Vantage Rotating thrust washer
*8	N/A	Vantage Fixed thrust washer
*9	N/A	Vantage Rotating head spring
10	005-602-5600-00	Vantage Nozzle Jet Inserts 1/8" , 1/4" , 3/8"
11	005-602-5602-00	Vantage Nozzle Jet Inserts 1/4" , 3/8" , 1/2"
12	004-602-5020-XX	Vantage Rotating Nozzle (Includes Nozzle Jet Inserts) (XX=Color Code)
	004-602-5024-XX	Vantage Fixed Nozzle (Includes Nozzle Jet Inserts) (XX=Color Code)
*13	N/A	Vantage Body
*14	N/A	Vantage Trim Ring (xx-color code)
15	005-252-1322-00	EII 90° 2X2 1/2 (32 pcs)

* NOT AVAILABLE FOR PURCHASE SEPARATELY

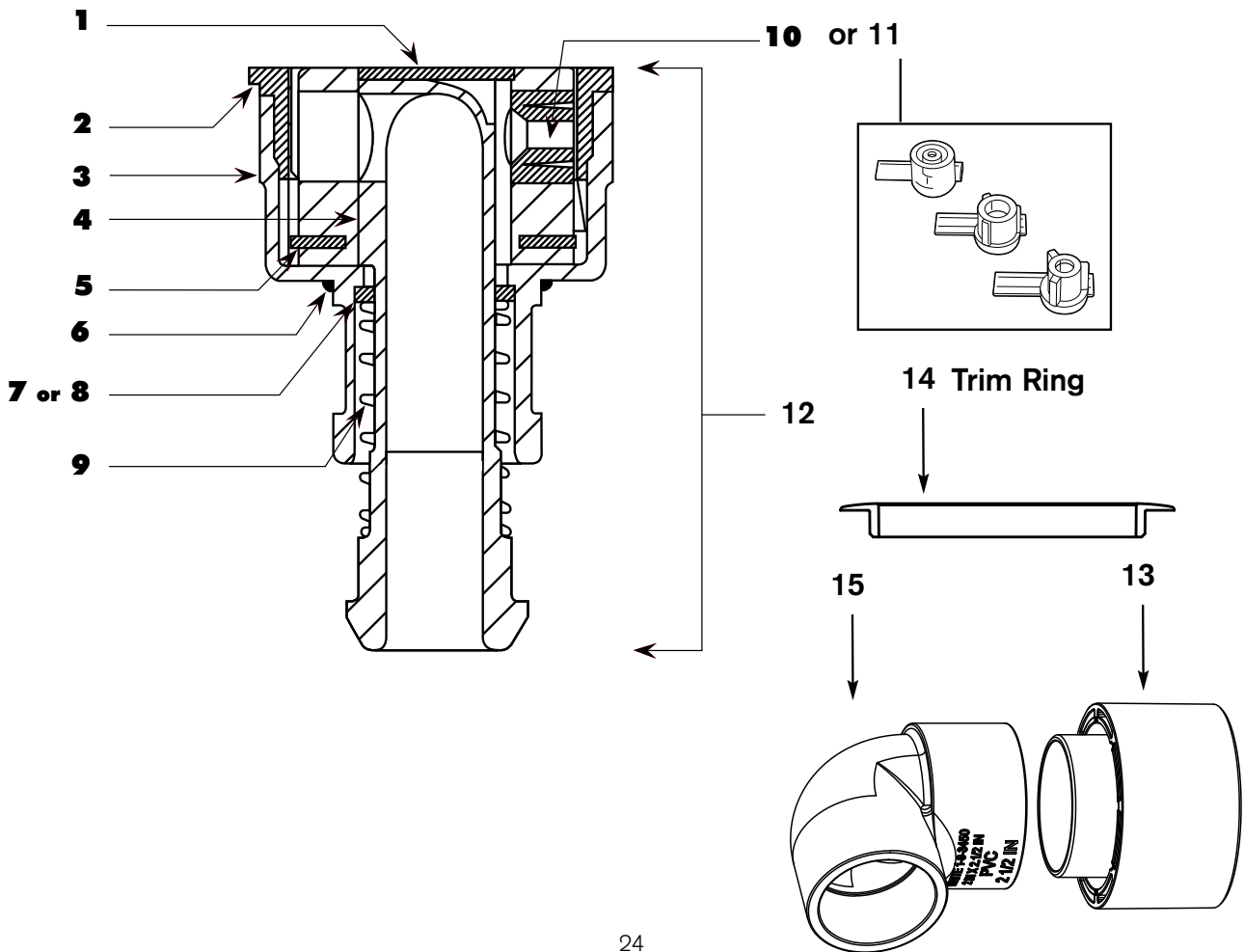

BILL OF MATERIALS

NOZZLE & BODY DIAGRAM

ITEM	PART NO.	DESCRIPTION
1	006-602-6052-XX	Vantage Step Single Head Kit (XX=Color Code)
*2	N/A	Vantage Trim Ring (XX=Color Code)
*3	N/A	Vantage Step Body
*4	N/A	Vantage Step Nozzle Caps (3pcs) (XX=Color Code)
*5	N/A	Vantage Step Nozzle Retainer O-ring 2-138 silicone (4 pcs)
*6	N/A	Vantage Nozzle (with caps) (XX=Color Code)

* NOT AVAILABLE FOR PURCHASE SEPARATELY

