

Filter Head Loss Curve

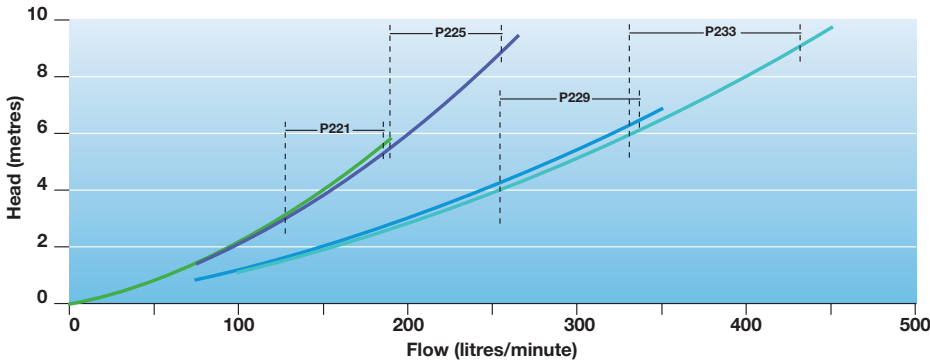

Disclaimers Every endeavour has been made to publish the correct details in this leaflet. No responsibility will be taken for errors, omissions or changes in product specifications. All performance data taken at sea level.

Operating Conditions

Fluid:	Water
Maximum working pressure:	280 kPa*
Water temperature range:	5°C – 38°C
Ambient temperature:	55°C maximum

*Cycle tested to greater than 45,000 cycles
Note: Not suitable for in-floor cleaning systems.

Multiport Valve

Component	Material
Type:	6 port
Body:	ABS
Handle:	ABS
Dowel pin:	304 stainless steel
Rotor:	Glass filled polypropylene
O-rings:	Nitrile
Sight glass:	Polycarbonate
Spider gasket:	Santoprene
Spring:	304 stainless steel
Washers:	304 stainless steel
Barrel unions:	ABS

Note: Some PVC jointing compounds are incompatible with ABS possibly causing failure to the product.

Filter

Component	Material
Filter body:	High density polyethylene
Lateral:	ABS
Hub:	ABS
Centre stem:	UPVC
Tank clamp:	304 stainless steel
Pressure gauge:	50mm diameter glycerine filled
	bottom mount
Thread	1/4" BSPT male
Range	0 – 270 kPa

Line Drawings

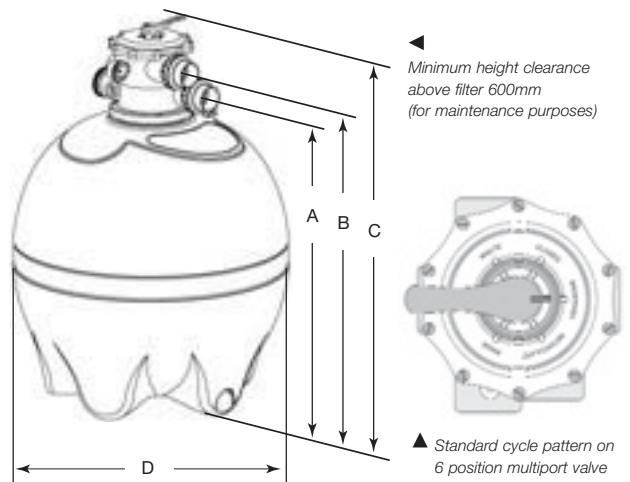

Dimension Table

Filter Valve Model	A Return Waste	B Pump	C Overall Height	D Diameter	D Service Height
P221 SR14965-A003	685	755	840	535	1440
P225 SR14965-A003	805	875	960	635	1560
P229 SR14971-TM-22-L	858	940	1090	735	1690
P233 SR14971-TM-22-L	938	1020	1170	835	1770

Note: All dimensions in mm.

Connection Type	Dimensions	
	P21, P25	P29, P33
Pump connection:	40mm slip PVC	50mm slip PVC
Return connection:	40mm slip PVC	50mm slip PVC
Waste connection:	40mm BSP male	50mm slip PVC

Note: Unless specified otherwise, all dimensions in mm.

Filter Data

Filter Model	Max Flow Rate (lpm)	Min* Flow Rate (lpm)	Sand QTY (kg)	Sand Grade	Zelbrite Amount (kg)	Filter Area (m²)	Multiport Valve (mm - ports)	Max Pressure (kPa)
P221	165	125	90	16/30	70	0.205	40	280
P225	235	175	140	16/30	105	0.293	40	280
P229	320	240	185	16/30	140	0.397	50	280
P233	415	310	220	16/30	165	0.517	50	280

*Minimum flow rate required for sufficient backwash of filters

Domestic flow rate based on filtration rate of 50m³Hr/m² of filter area. Commercial applications require a filtration rate between 15m³Hr/m² and 30m³Hr/m².



Rainbow Pool Products

PO Box 2388, Mansfield Qld 4122
Telephone STD 61-7-3849 5385
Facsimile STD 61-7-3849 5384
Email: info@rainbowpoolproducts.com.au
Web: www.rainbowpoolproducts.com.au