

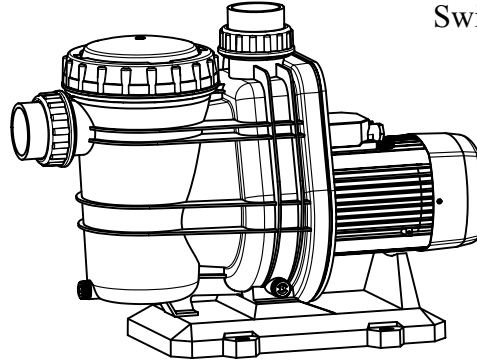

**WHISPER Series
TYPHOON C-Series
TYPHOON T-Series**

Swimming Pool Pumps

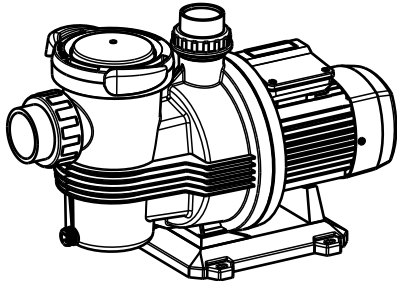



Instruction manual

Safety precautions

This symbol  together with one of the following words "Danger" or "Warning" indicates the risk level deriving from failure to observe the prescribed safety precautions:

 **DANGER** risk of electric shock Warns that failure to observe the precautions involves a risk of electric shock.

 **DANGER** Warns that failure to observe the precautions involves a risk of damage to persons and/or things.

 **WARNING** Warns that failure to observe the precautions involves the risk of damaging the pump and/or the plant.

1. General

The purpose of these instructions is to ensure the correct installation and best performance of our pumps.

These are single cell centrifugal pumps with built-in filter elements, especially designed for prefiltering and recirculation of water in swimming pools.

They are designed to operate with clean water at a maximum temperature of 40°C. All materials used are of top quality; they are subjected to strict, controls and verified to extremely demanding standards.

Correct compliance with the installation and operation instructions, and with the electrical connection diagrams, will prevent motor overloads and the consequences of all types that could otherwise result, consequences for which we decline all responsibility.

 **The appliance is not intended for use by young children or infirm persons without supervision. Young children should be supervised to ensure that they do not play with the appliance.**

2. Installation

 The installation of our electric pumps is only permitted in swimming pools or ponds that meet DIN standards VDE 0100 part 702/11.82. In case of doubt, inquire with an expert.

The pump should be installed as near as possible to water level, in horizontal position, in order to obtain a minimum suction path and reduce head losses.

It is not advisable to install the pump at more than 3 m geometrical height from water level.

Independently of the geometrical height and the power of the model chosen, self-priming times may be up to 10 min.

The pump must be fixed on a firm base, with screws of 6 or 8 mm diameter, through the prepared holes in the foot.

The pump should be protected from possible flooding and receive dry ventilation. The pump is to be installed in a manner consistent with the National Wiring Rules.

3. Installing the lines

The supports of the suction and discharge lines will be independent of those of the pump.

In the case of plastic lines, ensure tightness of joints and threads with TEFLON tape alone. Glue or similar products should not be used.

The suction line should have a diameter equal to or greater than that of the suction mouth of the pump.

The inside of the suction and discharge holes is threaded to a certain depth. This depth should not be exceeded when screwing on the respective lines. Only new or clean connectors should be used.

The suction lines should be structured with a slight slant to prevent the formation of siphons.

4. Electrical connection

 The electrical installation should have a multiple separation system with contact opening of a least 3 mm.

The protection of the system will be based on an RCD (I_{fn} = 30 mA). If outdoor operation is foreseen, the power supply cord should meet EEC standards (2) or be of type H07 RN-F as per VDE 0250.

Single-phase motors will be equipped with built-in thermal protection. In the case of three-phase motors, the user should provide thermal protection complying with the installation rules in force.

The diagrams in Fig. (1) will allow correct electrical connection.

5. Verifications prior to initial start-up

 After making the connections defined in the preceding section, unscrew the filter cover and fill the pump prefilter with water to the bottom level of the suction line.

Verify that the pump shaft turns freely.

Verify that the mains voltage and frequency match those specified on the nameplate of the pump.

Set the prefilter cover back in place and screw it to a suitable tightness.

Check that the turning direction of the motor matches that specified on the fan cover. In three-phase motors, if the turning direction is incorrect, reverse two supply phases on the protection panel.

If the motor does not start, try to determine the cause of the irregularity by consulting the list of common faults and their possible solutions, provided in this manual.

NEVER RUN THE PUMP DRY.

6. Starting

Open all the gate valves and put the motor under voltage. Wait a reasonable time to allow self-priming. Verify the breakaway current and suitable adjust the thermal relay.

7. Maintenance

 Our pumps do not require any specific maintenance. It is advisable, however, to periodically clean the pump filter and to empty the pump housing in low-temperature periods through the blowoff plug. If the pump is to remain idle, it is advisable to empty and clean it, and then reinstall the filter cover with a ring lubricant on the rubber gasket, taking measures to ensure that the place where the pump is to be stored will remain dry and ventilated.

In the event of breakdown, the user must in no event handle the pump, but must contact an authorised technical service.

When the time comes to dispose of the pump, it contains no toxic or contaminating materials. The principal components are duly identified for selective breaking.

If the supply cord is damaged, it must be replaced by the manufacturer or it's service agent or a similarly qualified person in order to avoid a hazard.

SINGLE PHASE SUPPLY

- 1 - RED
- 2 - WHITE
- 3 - BLACK
- 4 - CAPACITOR
- 5 - LINE
- 6 - MOTOR RELAY

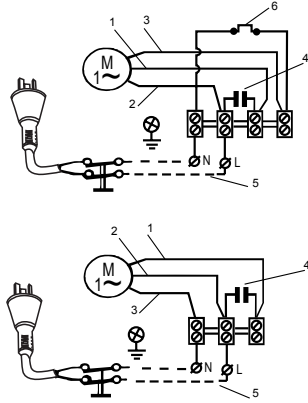

THREE PHASE SUPPLY

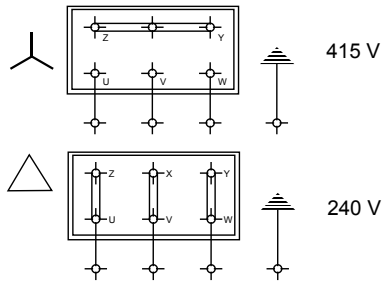
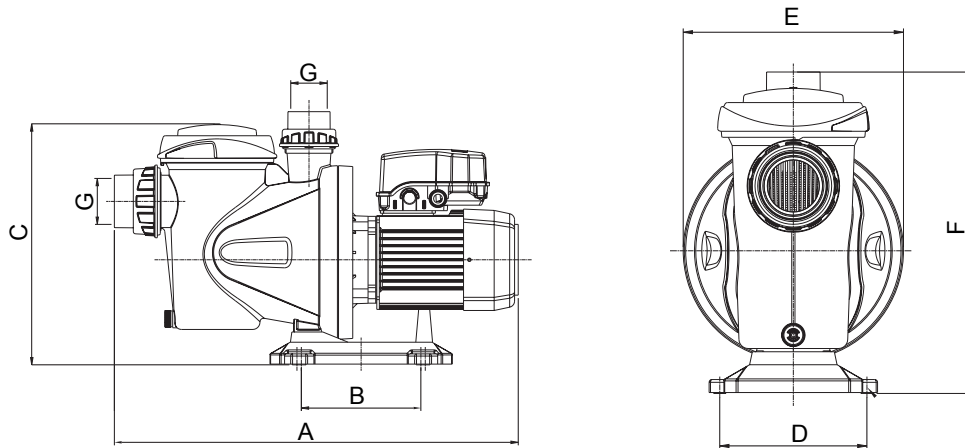
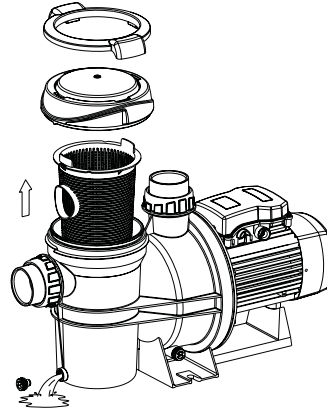
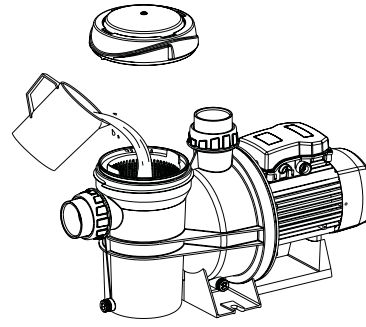

Fig. 1



230V 50Hz	Q max. (l/min)	H max. (m)	A 1 ~ 230V	A 3 ~ 230V	C - μF	P1 (kW)	IP	η (%)	Db _a ± 1	A (mm)	B (mm)	C (mm)	D (mm)	E (mm)	F (mm)	G (mm)	Kg
WHISPER 500M	180	12.2	2	1.1	12	0.45	55	35	<70	475	115	301	108	212	312	Ø48	7.4
WHISPER 750M	230	13.5	2.9	1.2	12	0.65	55	42	<70	475	115	301	108	212	312	Ø48	7.7
WHISPER 1000M	290	14	3.8	1.5	12	0.85	55	50	<70	475	115	301	108	212	312	Ø48	8.5
TYPHOON C50M	280	13.5	3.7	1.5	16	0.8	55	45	<70	532	170	345	159	238	330	Ø48	9.4
TYPHOON C 75M	340	15	5.5	2.2	16	1.2	55	47	<70	532	170	345	159	238	330	Ø48	10.7
TYPHOON C100M	380	16.5	6.2	2.5	16	1.5	55	48	<70	532	170	345	159	238	330	Ø48	11.4
TYPHOON C150M	430	18.5	7.1		25	1.6	55	55	<80	560	170	345	159	238	330	Ø48	13.5
TYPHOON T75M	416	15	4.8	2	25	1	55	40	----	613	200	397	231	429	270	Ø63	15
TYPHOON T100M	435	17	7	2.8	25	1.6	55	55	70	613	200	397	231	429	270	Ø63	16.5
TYPHOON T150M	500	19	8.5	3.1	25	1.9	55	61	71	613	200	397	231	429	270	Ø63	18
TYPHOON T200M	550	19.5	9.7	3.8	30	2.2	55	64	72	613	200	397	231	429	270	Ø63	20.7
TYPHOON T300M	650	22.5	12.5	5	60	2.6	55	63	73	613	200	397	231	429	270	Ø63	20.6

V/Hz esp.: See pump nameplate. Liquid Temperature: 4°C a 40°C. Storage temperature: -10°C a +50°C. Relative Air Humidity: 95% Max. Motor classe: I
H max refers to the maximum total head in metres.

POSSIBLE FAULTS, THEIR CAUSES AND SOLUTIONS

	1	2	3	4	5	POSSIBLE PROBLEM	SOLUTIONS
1) Pump does not prime.	X	X				Air entry through suction line.	Verify condition of connectors and gaskets of suction line.
2) Pump supplies scant flow.	X					Inadequate airtightness of filter cover.	Clean the filter cover and verify condition of rubber gasket.
3) Pump noisy.	X	X				Motor turning direction reversed.	Reverse 2 phases of the supply.
4) Pump does not start.	X	X				Excessive suction height.	Set pump at a suitable level.
5) Motor makes sound but does not start.	X	X		X		Incorrect voltage.	Verify the voltage specified on the nameplate and that of the mains.
	X					No water in prefilter.	Fill prefilter with water.
	X					Suctioning out of water.	Set suction in correct position.
		X				Filter clogged.	Clean filter.
		X	X			Diameter of suction line smaller than required.	Correctly dimension suction line.
		X				Discharge clogged.	Inspect filter and discharge line.
			X			Incorrect pump attachment.	Attach pump correctly.
			X			Foreign body in pump.	Clean pump and inspect its filter .
				X		Thermal relay tripped.	Reset thermal relay.
				X		Lack of power.	Reset the fuses.
				X	Motor blocked.	Remove the motor and call the Technical Service.	

If the supply cord is damaged, it must be replaced by the manufacturer or it's service agent or a similarly qualified person in order to avoid a hazard.



DAVEY WATER PRODUCTS GUARANTEE FOR AUSTRALIA & NEW ZEALAND

This Davey product is guaranteed to be free of material or manufacturing defects at the time of original purchase. Should any part fail as a result of such defects within three years of original purchase, the product will be repaired free of charge.

TERMS AND CONDITIONS

1. This guarantee applies to all states and territories of Australia and New Zealand only and is subject to the provisions of the Trade Practices Act (Aust.), the Goods and Consumer Protection Legislation of the various Australian states and the Consumers guarantee Act 1993 (NZ) as applicable.
2. The guarantee period commences on the date of original purchase of the equipment. Evidence of this date of original purchase must be provided when claiming repairs under guarantee. It is recommended you retain all receipts in a safe place.
3. This guarantee covers parts and workshop labour only. Goods should be forwarded, with proof of date of original purchase, to an Authorised Davey Service Centre freight paid. Any travel and removal/reinstalling charges for goods repaired infield will be to the owners account. Guarantee may be denied on goods not readily accessible for service personnel or mounted on exterior walls above single storey level.
4. This guarantee is subject to due compliance by the original purchaser with all directions and conditions set out in the Installation and Operating Instructions. Failure to comply with these instructions, damage or breakdown caused by fair wear and tear, negligence, misuse, incorrect installation, chemical or additives in the water, inadequate protection against freezing, rain or other adverse weather conditions, corrosive or abrasive water, lightning or high voltage spikes or through unauthorised persons attempting repairs are not covered under guarantee. The product must only be connected to the voltage shown on the nameplate.
5. Without limiting the original purchaser's entitlements under the Trade Practices Act (Aust.), the Goods & Consumer Protection Legislation of the various Australian states, or the Consumers Guarantee Act 1993 (NZ), Davey shall not be liable for any loss of profits or any consequential, indirect or special loss, damage or injury of any kind whatsoever arising directly or indirectly from the product or any defect.
6. Where the Trade Practices Act (Aust.), the Goods and Consumer Protection Legislation of the various Australian states and the Consumers Guarantee Act 1993 (NZ) does not apply. Davey shall not be liable for any loss of profits or any consequential, indirect or special loss, damage or injury of any kind whatsoever suffered by the purchaser arising directly or indirectly from the product or any defect and the purchaser shall indemnify Davey against any claim by any other person whatsoever in respect of any such loss, damage or injury.

7. Nothing in this guarantee is intended to have the effect of contracting out of the provisions of the Trade Practices Act (Aust.), the Goods and Consumer Protection Legislation of the various Australian states and Consumers Guarantee Act 1993 (NZ) except to the extent permitted by the various Acts and this guarantee is to be modified to the extent necessary to give effect to that intention.
8. Davey may be collecting personal information from you in order to provide you with a service. Davey Water Products Pty Ltd promises only to use this information in accordance with the Provisions of the Privacy Act 1988 (Cth) and the Privacy Policy of Davey Water Products Pty Ltd which is available at davey.com.au.

© Davey Water Products Pty Ltd 2008.

® Davey and Typhoon are registered trademarks of Davey Water Products Pty Ltd.



Rainbow Pool Products

PO Box 2388, Mansfield Qld 4122

Telephone STD 61-7-3849 5385

Facsimile STD 61-7-3849 5384

Email: info@rainbowpoolproducts.com.au

Web: www.rainbowpoolproducts.com.au