

CHEMIGEM DM52 WITH PUMPS

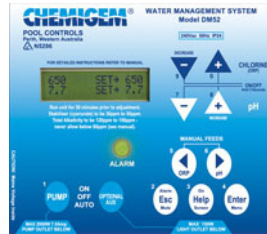

Code

Description

1 Year Warranty

00052005

Chlorine and pH controller suitable for most pools, with built-in pool circulation pump timer. Supplied with 12V peristaltic pumps having a pressure limitation of 40 kPa.

THE TRUSTED NAME IN POOL MANAGEMENT

Pool water must be sanitised to remain safe. Chlorine is used for this purpose, but for it to be effective the pH and other factors must be optimally set. For decades these chemicals have been dosed by hand (and some pool owners still do) with the result being unmatched chlorine and pH levels. This hit and miss method resulted in the use of far more chlorine and acid than was necessary and offered variable sanitation quality for the pool. Then Chemigem was invented – a device which measured the pH and a new concept called ORP – or Oxidation Reduction Potential. The Chemigem controller measures these water quality parameters and makes a decision about whether to add chemical or not – and it makes these decisions about 30 times each hour. Gone is the hit-and-miss of hand dosing, gone is the variability of water sanitation – the era of automated water quality control has arrived.

TAKE THE GUESS WORK OUT OF ADDING CHEMICALS

The Chemigem measures pH and ORP to keep your pool water healthy. pH is a measure of the acidity of the pool water, while ORP is a measure of the effectiveness of the chlorine in the water. Even though two pools may have the same measured chlorine residual, the pool with the correctly set pH is the one safe for your children to swim in. With Chemigem the effectiveness of the chlorine is no longer a guess – it is a measured pool water quality parameter that you the user are able to set.

LIKE AN INDUSTRIAL PROCESS CONTROLLER FOR YOUR POOL

Chemigem uses an advanced FLASH-based processor with proprietary algorithms to watch over your pool and filtration system functions. There is a versatile control system for operating and programming. The LCD display shows you the condition of your pool water and what Chemigem is doing about it. The display is also used to provide information about the timer. If the unit is turned on for a quick swim and the user forgets to turn it off afterward it will simply turn off at the next programmed off time. There is even a provision for running the unit for a set period from 1 to 48 hours – great for a quick swim, filtration boost or superchlorination. The unit will even allow an external timer to take control if a home/pool automation system is already installed.

THE VERSATILITY OF DIFFERENT MODELS OFFERING ALTERNATIVE CHEMICAL DELIVERY SYSTEMS

Chemigem has two main versions – the DM52 for domestic pools and the CM55 for large commercial pools. Each of these versions can control various ways of feeding chemicals into the pool water flow: vacuum valves (with/without venturi injectors), peristaltic pumps (12V and 240V) and even solenoids for erosion feeders.

Chemigem also come in models that can control Salt Water Chlorinators for pool owners that like that method of sanitation.

GENERAL DATA: DIMENSIONS, ELECTRICAL, APPROVAL

Chemigem Model	Primary Use	Sensing	Injection / Control Method	Clock / Timer
DM52	General / Domestic Pools	Dual Probe (pH +ORP)	Vacuum Valves	Yes - Switched Pump Outlet
DM52VP	General / Domestic pools with Salt Chlorinator	Dual Probe (pH +ORP)	Acid Valve + Switched SWC Socket outlet	Yes - Switched Pump Outlet + SWC outlet
DM52pH	Geral / Domestic Pools	pH Probe	Vacuum Valve or 12V Peristaltic Pump	Yes - Switched Pump Outlet
DM52CHL	Geral / Domestic Pools	ORP Probe	Vacuum Valve or 12V Peristaltic Pump	Yes - Switched Pump Outlet
DM52 w/ pumps	Geral / Domestic Pools	Dual Probe (pH + ORP)	Vacuum Valves / Chemical Pumps	Yes - Switched Pump Outlet

Dimensions	Enclosure			Mounting Holes Centres		Electrical Information (App. RCM N5296)	
	Width	Height	Depth	Post	Wall	Volts 230 - 250V, 50Hz IP24	
DM52 Series	190 mm	180 mm	125 mm	50 mm	140 mm	Power	All Models < 0.05 kw

INSTALLATION & OPERATION MANUAL

CAREFULLY READ THE ENTIRE CONTENTS OF THIS MANUAL

CAREFULLY READ THE FOLLOWING POINTS BEFORE INSTALLING THE CHEMIGEM

WARNING It is important that the Chemigem is installed and operated in accordance with the instructions provided in this manual.

WARNING There is the risk of electric shock. Ensure all connections from the Chemigem to the electricity supply are made in accordance with local safety codes.

WARNING Do not bury any electricity supply cords unless strictly following local safety codes. Locate all cords, wires and tubes away from places where they may become damaged by garden equipment.

WARNING The Chemigem contains microprocessors that may be disturbed by the operation of electrical devices within a 5 metre radius.

WARNING The Chemigem must be connected so that it only operates when the pool pump is running, otherwise incorrect pool water readings will occur and concentrated chemicals may flow into the pool water pipes and/or the chemical drums, where they can mix and produce poisonous Chlorine gas.

WARNING Before operating the Chemigem, bring the pool water chemical levels to within the ranges given in this manual, but pay attention to the specific requirements of the pool builder.

WARNING To ensure the desired chemical levels are being maintained, check the pool water with a good quality test kit. This should be performed daily for the first two weeks and on a regular basis thereafter.

WARNING Always take water samples from a point near the skimmer box, for this is where the water is completely mixed, giving the most accurate readings. Never take water samples near the pool returns (“eye-balls”) where the Chemigem may have freshly dosed the pool water.

WARNING It is very important that the reagents in the test kit are well within their use-by date, otherwise false readings may result. If in doubt, take a water sample to a pool shop for testing.

WARNING Chemicals must be carefully diluted according to the size of the pool or spa. Always add the concentrated chemical to the water and never add the water to the concentrated chemical. Some chemicals react violently with water and can splash into face and eyes. Always wear protective face-shield and gloves for such operations. Fully observe all the chemical manufacturer’s safety instructions when handling pool chemicals.

WARNING Ensure the chemical supplies (liquid Chlorine and pool Acid) are kept in visually different containers to avoid wrong connection. Use colour or size differences or both. When these two concentrated chemicals are mixed together out of the pool water, poisonous gas is produced.

WARNING If it is decided to turn off the Chemigem audible alarm for any reason, the unit will no longer have that warning capability and the pool owners will have to rely on their own ability to monitor the indicator lights on the face of the unit to verify that the Chlorine and pH levels are within acceptable limits.

SAVE THESE SAFETY INSTRUCTIONS

MESSAGE TO NEW OWNER

Ensure that the Unit Matches the Mains Power

The Chemigem requires a mains supply of 220/250 volts AC

Although the unit has an in-built surge protector, it is recommended that a voltage surge protection device be fitted to the electricity supply.

Prior to Installation and Operation

It is important that a full water test is carried out with a good quality test kit and that the pool water is correctly balanced prior to the installation and operation of the Chemigem. The pool builder often includes the first amounts of chemicals. These are estimated and sometimes require adjustment.

Chemigem Installation and Operation

The unit is one of the most advanced pool chemistry controllers of its kind. It is important that it is installed and operated in accordance with the instructions provided in this manual. The Chemigem is designed to automatically assist in keeping the levels of Chlorine and pH correctly balanced in swimming pools and spas. It continuously monitors and adjusts pH and Chlorine levels required through state of the art solenoid valves, utilising the natural suction of the pool recirculating pump while the pool pump is running adds Chlorine and pool Acid as and when required. Stable controlling of the Chlorine and pH levels of the pool water should be achieved during the first two weeks of operation. During this period, check the level of Chlorine, Total Alkalinity and pH regularly with a good quality test kit to confirm that the unit is keeping to the desired levels. The chemical levels are set by the keypads. Once the correct positions have been set for the pool water they should remain constant and do not have to be changed from season to season (however in winter the pool pump running times can be reduced)

Electronic Clock

The in-built electronic clock requires setting to your local time. To set the clock, (Refer to page 23).

Pool Pump Times

The factory-set pool pump times are on page 23. To change pumping times or to turn the timer off, (Refer to pages 22&23).

Pool Water Circulation

To enable the Chemigem to work efficiently, the mixing of the pool water has to be as quick and complete as possible. Positioning the return nozzles (eyeballs) to the pool so that the main water-body rotates is the best way to achieve this. Under no circumstances should the eyeballs be positioned to produce opposing circulation patterns. The unit's multi-electrode (probe) monitors the Chlorine and pH levels as the water travels towards the pump.

If the mixing of the pool water is slow, the multi-electrode (probe) will not receive the signal until large amounts of chemicals have been added to the water. When the multi-electrode (probe) finally receives the signal, the pool water may be overdosed and the excess warnings will operate.

Heated Pool

If the one pool pump is required to service both the pool heating system and the Chemigem, the pool heating plumbing must be bypassed. (Refer to pages 12&16)

PREPERATION

ITEMS SUPPLIED

A brief description of the items supplied and the purpose of each item:

Chemigem

The sealed unit is connected to the solenoid valves and assists in keeping the levels of Chlorine and pH correctly balanced in swimming pools and spas.

Key features:

- A computerised on-screen HELP menu
- An automatic pool pump timer
- An easy-to-read screen showing chemical settings and actual chemical readings
- Indicator light and audible alarm that monitor whether pool water chemical levels are within the required range

Multi-Electrode (probe)

The one Multi-Electrode (probe) is fitted into the side arm of the tapping band that is then clamped around the PVC pipe running from the pool to the pool pump. The one multi-electrode (probe) monitors both the Chlorine and pH levels. It is mounted into the tapping band on the inlet (suction) side of the pool pump. Chemical readings obtained by the multi-electrode (probe) are monitored by the Chemigem, resulting in Chlorine and/or pool Acid being dosed into the pool water as and when required via the solenoid valves and tapping band injector nozzle.

Tapping Band

The tapping band is inserted into the PVC pipe on the inlet (suction) side of the pool pump. The purpose of the tapping band is to house the Multi-Electrode (probe) and to provide an injector nozzle for chemicals being dosed into the pool water via the solenoid valves.

Solenoid Valves

The solenoid valves contain the only two moving parts in the Chemigem package. The purpose of the solenoid valves is to control the flow of Chlorine and/or pool Acid from the chemical drums as and when required and to inject the chemical(s) into the pool water via an injector nozzle on the tapping band.

Coil of Plastic Tubing

The plastic tubing is connected from the solenoid valves to the chemical drums and the tapping band.

Filters

There are two types of filter:

- In-Line Filter
- Drum Filter

The In-Line Filters are connected to the plastic tubing for both the Chlorine and pool Acid tube lines, between the respective chemical drums and the solenoid valves. The Drum Filters are connected to the plastic tubing. One is placed in the Chlorine drum and the other is placed in the pool Acid drum.

Sinkers

The Sinkers are fitted above the Drum Filters. The purpose of the sinkers is to provide added weight to the Drum Filters so that the filters do not float and remain positioned close to the bottom of the chemical drums.

Wall Anchors and Screws

There are two wall anchors and screws for the affixing of the unit to a solid surface. Wall anchors and screws are also supplied to affix the solenoid valves to a solid surface surface.

TOOLS REQUIRED

The following is a list of tools required together with the purpose for each tool:

19mm Hole Saw

To drill a hole in the PVC pipe for the fitting of the tapping band.
A hole saw can be purchased from most hardware stores Spirit Level
For fitting the Chemigem horizontally to a solid surface.

Electric or battery charged drill

For drilling screws to hold the Chemigem and Solenoid valves

Drill Bits

- 5mm masonry drill bit for wall anchors (Refer to page 9)
- 3mm twist drill (for metal sheet or wood fixing)
- 10mm drill (for making holes in the lids of chemical drums)

Knife

For cutting the plastic tubing to required lengths

Screwdriver

For affixing self tapping screws

Tape Measure

To measure for the location of Chemigem components

Wrench

For tightening the tapping band. (Refer to page 10)

OTHER ITEMS REQUIRED

Other items required together with a brief description of the purpose of the items:

Pool Water Test Kit

A good quality test kit is essential for testing the pool water.
The pool water must be tested and balanced before the Chemigem is turned on.

PVC Tape

For use on the chemical drums, solenoid tubing and loose wires.
Protective Face Shield and Gloves
For use when diluting chemicals.

Metal Cover

An optional metal cover can be purchased from the supplier of the Chemigem.

INSTALLATION

LOCATION

For ease of installation and for safety, the Chemigem must be installed as follows:

- In a normal upright position (with the printing on the front reading horizontally) and protruding cords facing toward the ground.
- Attached to a solid vertical surface to provide easy access to the power supply and should preferably be fixed at eye level.

To obtain maximum life for the unit it is recommended that it be located in a sheltered and shaded position. Should this not be possible, an optional metal cover can be purchased. (special procedures required for the placement of Chemigem when the pool pump and filter are located below pool water surface level and when the pool has a heater unit). Devices such as cell-phones, radios and portable CD players, are capable of emitting radio waves that may interfere with the correct operation of the Chemigem. Avoid using these devices within a radius of 5 metres of an operating Chemigem.

POWER CONNECTION

It is important that the Chemigem only operates when the pool pump is running. To ensure this happens, plug the pool pump into the socket in the base of the Chemigem and then plug the Chemigem into the power supply. If the Chemigem is left switched on when the pool pump is off, the Multi Electrode (Probe) will quickly pick up false readings from the non-moving water and signal warnings until the unit is switched off.

CHEMIGEM INSTALLATION

Position the Chemigem within 3 metres of the tapping band at a convenient height for easy operation, preferably at eye level. If it is impractical to install the unit at eye level because of site restrictions, install it at any height above the solenoid valves that provides ease of access and operation in a normal upright position (with the printing reading horizontally and protruding cords facing toward the ground). **The solenoid valves must be above the height of the chemical drums.**

TAPPING BAND INSTALLATION

Air Leaks

Before commencing the installation of the tapping band, check for air leaks in the suction line by switching on the pool pump and checking the lint pot. If there are large quantities of air bubbles swirling around which do not clear within 2 to 3 minutes, it is likely the system has an air leak in the suction line between the pool and the pool pump. If a pool-cleaning device is in use, carefully check the flexible hose for small pinholes that allow the entry of air into the suction line.

INSTALLATION

Turn off the pool pump before commencing the installation of the tapping band. Refer to the diagrams on pages 12 and 13 showing:

- The components to be connected to the PVC pipe.
- The connection of the multi-electrode (probe) to the tapping band.
- The location of the multi-electrode (probe) and tapping band.

It is imperative to fit the tapping band to the inlet (suction) side of the pool pump unless using a venturi system. The required range of pressure/suction is negative 20 kPa to negative 70 kPa. After selecting the position for the tapping band on the pool pump inlet pipe, ensure that it is as near as possible to the pool pump.

When the Chemigem is working it is essential that the multi-electrode (probe) and injector nozzle be in a rapidly moving water stream. If not, the unit will display incorrect and erratic readings and may cause excess additions of concentrated chemicals.

The tapping band can be positioned on either horizontal or vertical pipes, provided the multi-electrode (probe) is fitted exactly horizontally.

- If the multi-electrode (probe) is positioned with the sensor tips aiming downwards it will trap air bubbles.
- If the multi-electrode (probe) is positioned with the sensor tips aiming upwards it will trap dirt or debris.

Both of these positions will cause erratic and false readings of the swimming pool chemical levels.

Drilling the Tapping Band Holes

- Drill a hole using a 19mm hole-saw through both sides of the PVC pipe.
- Ensure the surround to the hole at the "O" ring contact is smooth and clean.
- Fit the tapping band, first checking that the "O" rings are in position and that the arrow on the tapping band points toward the pool pump.

Do not use grease or sealing compound on this fitting.

To check the accuracy of the tapping band position look through the multi-electrode (probe) arm (feel with your finger or use a mirror if the position is inaccessible) making sure the multi-electrode (probe) is lined up exactly with the holes. Tighten by hand and then give the nuts half a turn with a wrench. If the tapping band is over tightened it will split.

Inner Shell of Tapping Band

The inner shell of the tapping band is used if the PVC pipe has a 40mm diameter. If 50mm diameter PVC pipe is used, the inner shell of the tapping band is not required.

MULTI-ELECTRODE (PROBE) INSTALLATION

- Remove the multi-electrode (probe) protective cap, before fitting the multi-electrode (probe) to the tapping band.

The protective cap should be retained for possible future use.

- Fully insert the multi-electrode (probe) (with "O" ring fitted) into the tapping band and hand tighten only.

Do not use grease or sealant on this connection to avoid contaminating the sensing part of the multi-electrode probe.

SOLENOID VALVE INSTALLATION

- The valves must be fitted as near as possible to the tapping band
- The valves must be screwed to a vertical surface above the top of the chemical drums and no more than 750mm from the ground so that the pool pump may easily raise the chemicals from the drums.
- To meet special needs, a Venturi system can be connected to the solenoid valves.

SOLENOID VALVE TUBING INSTALLATION

- Connect a length of tubing between the centre nipple on the solenoid valve base and the tapping band injector nozzle
- Connect a length of tubing to the Chlorine in-line filter and lay it neatly to the Chlorine drum
- Connect a length of tubing to the pool Acid in-line filter and lay it neatly to the pool Acid drum

Ensure that the tubing is absolutely clean and free from sand and dirt before fitting, as particles may enter the valve and cause leakage.

Do not use any tubing other than that supplied. To do so may result in damage to the Chemigem and negate the Warranty. If additional tubing is required for the installation of the unit, it will be supplied at no cost.

CHEMICAL DRUMS INSTALLATION

Ensure the Chlorine and pool Acid are kept in visually different drums to avoid wrong connection. Use colour or size differences, or both.

Refer to the cutaway diagram of chemical drum on page 12 for a presentation of the following:

- Position the Chlorine and Acid drums in a safe and secure location about 2 metres from the Chemigem.
- Drill a 10mm hole in each of the screw-on drum caps (slightly larger than the diameter of the tubing) to allow venting and to prevent the drum walls from being sucked in as the chemicals are used.
- Pass each length of supplied tubing through the hole in the appropriate drum cap.
- Place the supplied sinkers onto the tubing and attach the appropriate drum filter.
- When placing the tubing into the drums, measure the tubing against the outside of each drum so that the drum filter will be 10-15mm above the bottom of the drum and then apply several turns of PVC tape at a point above the cap to prevent the tubing from slipping further into the drum.
- Lower the drum filter and sinker into the drum and screw on the cap.

FITTING CHEMIGEM TO A HEATED POOL

If the pool heating system is controlled by a separate pool pump, there are no factors that affect the installation of a Chemigem. If the one pool pump is required to service both the pool heating system and the Chemigem, the pool heating plumbing must be bypassed. This will necessitate the installation of a Venturi system at an additional cost.

FITTING CHEMIGEM BELOW POOL WATER SURFACE LEVEL

The following instructions assume the installer has some knowledge of the operation of the pool and the parts described. If the installer is not experienced in pool operation and maintenance, contact the supplier of the Chemigem or a qualified pool maintenance technician with any questions before attempting to carry out the steps described in this section.

The Chemigem must be installed within 3 metres of the tapping band and in an upright position and attached to a solid vertical surface, preferably at eye level. If it is impractical to install the unit at eye level because of site restrictions, install it at any height above the solenoid valves that provides ease of access and operation. The solenoid valves need to be above the height of the chemical drums.

When the pool pump and filter are fitted below the pool water surface level, the suction line may be under positive pressure even with the pump running. In this case an isolating valve must be fitted to enable the pump and filter to be serviced.

Fit the tapping band between the isolating valve and the pool pump and close the isolating valve sufficiently to obtain the required suction so as to allow the unit to operate effectively.

The required suction range is negative 20kPa to negative 70 kPa when the pool pump is running and the filter is clean.

Methods to obtain improved suction involve using venturi devices or orifice plates. Contact the supplier of the Chemigem or a qualified pool maintenance technician for information on these.

If the pool pump is more than one metre below the pool water surface it is essential to fit Non Return Valves into the chemical supply tubing to prevent back-flow into the chemical drums.

Failure to prevent the back-flow into the chemical drums would cause spillage from the drums, which in turn may result in the two concentrated chemicals mixing together out of the pool water and producing poisonous chlorine gas. **In addition, there is the serious possibility of personal injury from contact with the chemicals and breathing the fumes.**

VENTURI SYSTEM

A venturi system is required for:

- Special needs, such as fitting a Chemigem below the pool water surface level.
- Pools that are heated.

Pool Controls provides information on the installation procedure for a venturi system.

Pool Controls provides the venturi system at an additional cost.

NEATENING UP

Finish the installation by taping all loose wires and tubing together and place off the ground to prevent damage and possible electrical shorting.

INSTALLATION DIAGRAM

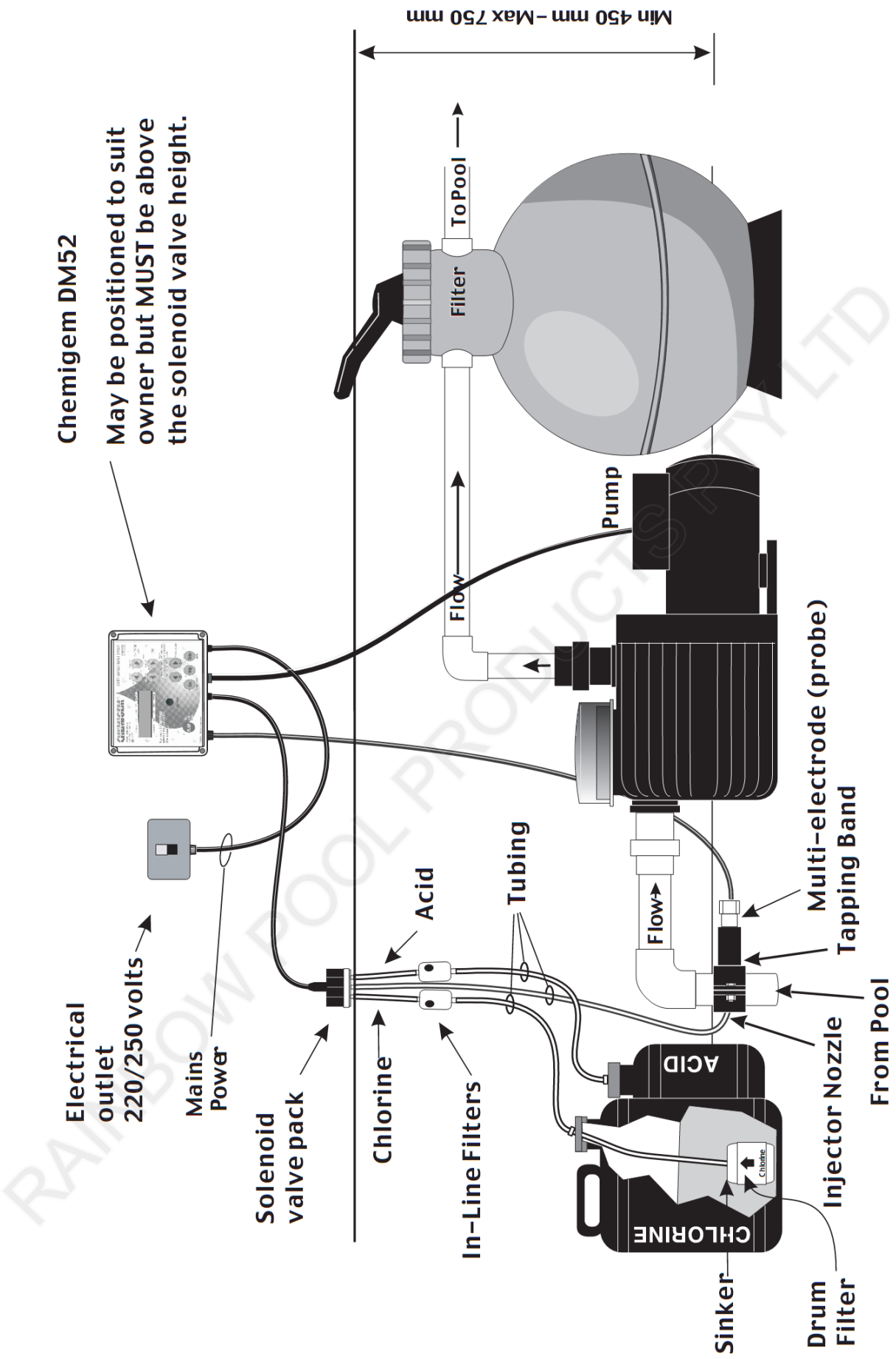

DRILLING TAPPING BAND HOLES

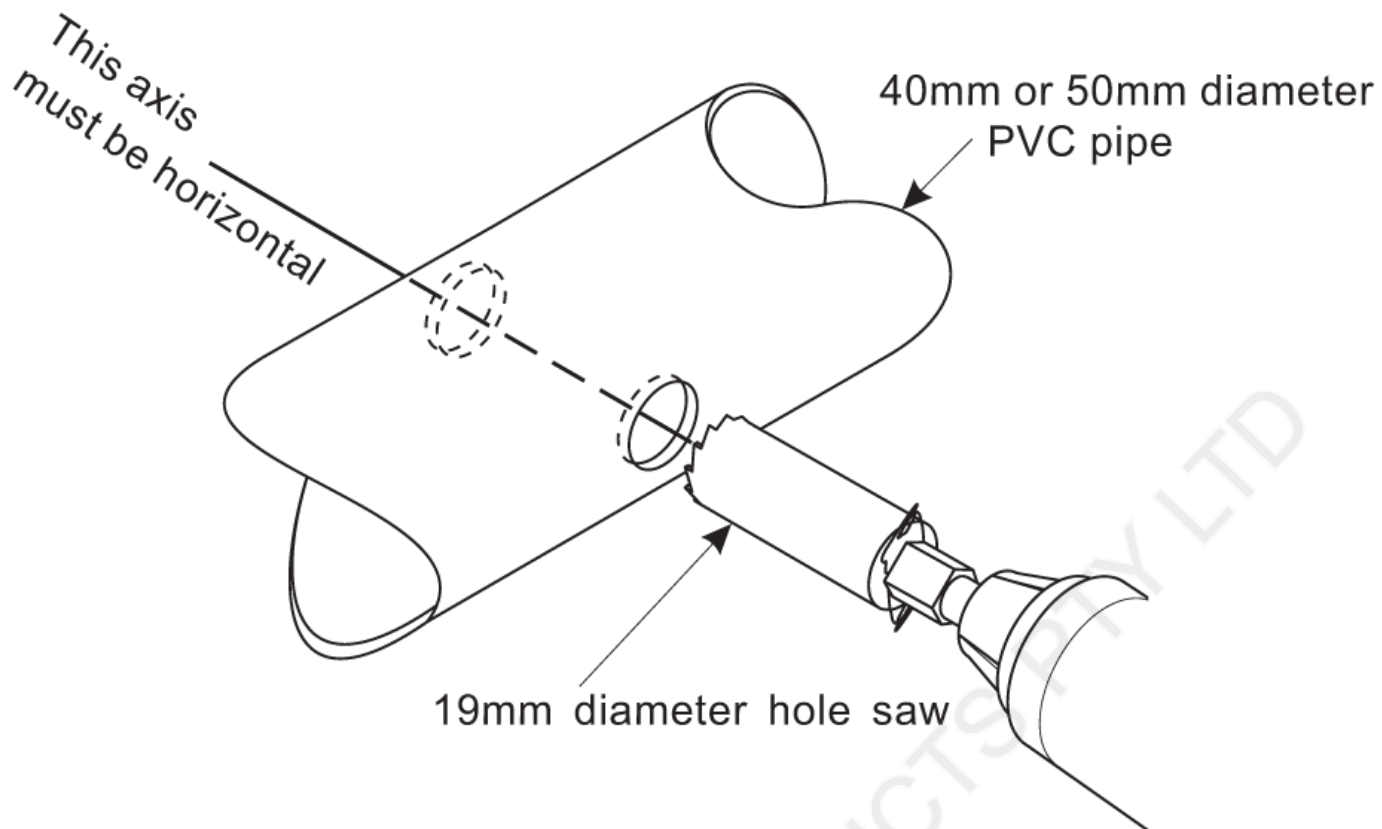

TAPPING BAND AND MULTI-ELECTRODE (PROBE)

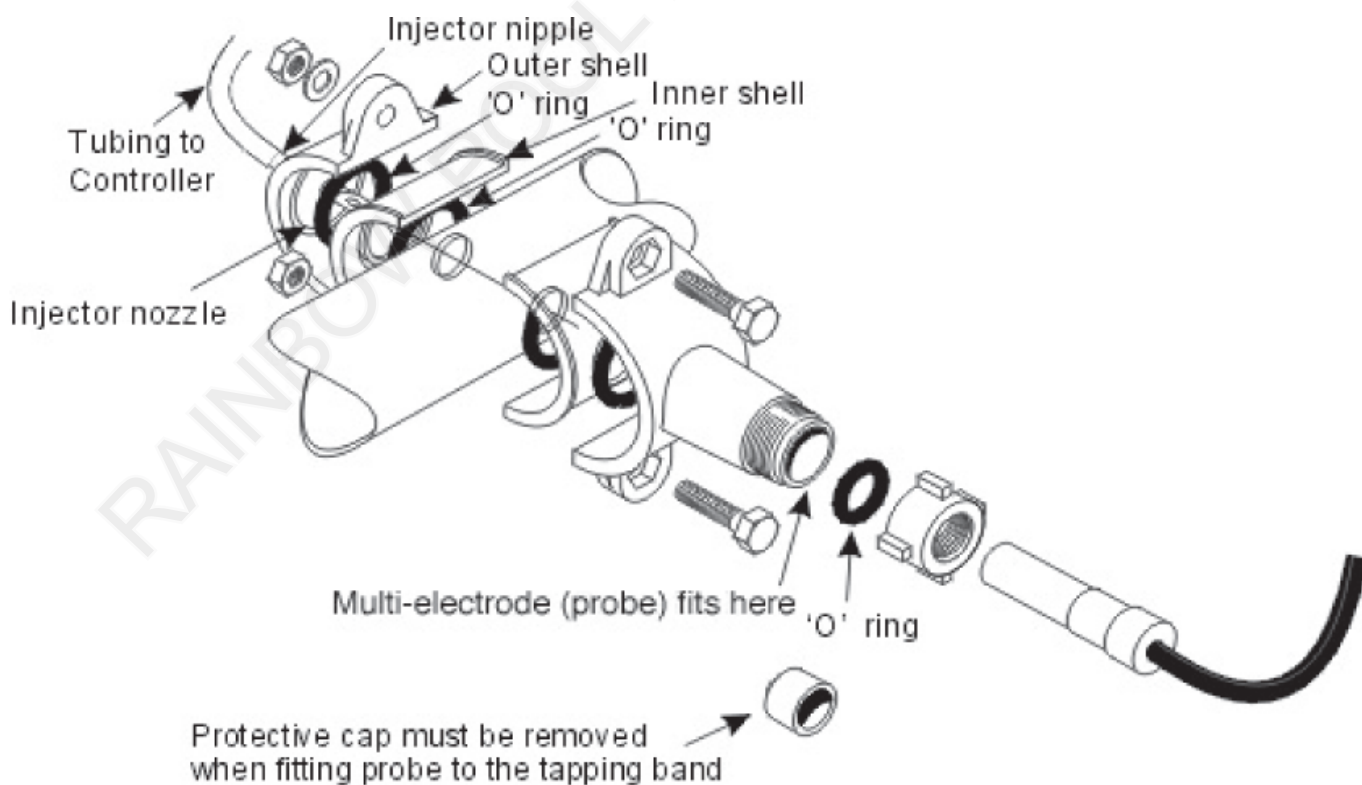

FITTING CHEMIGEM BELOW POOL WATER SURFACE LEVEL FITTING

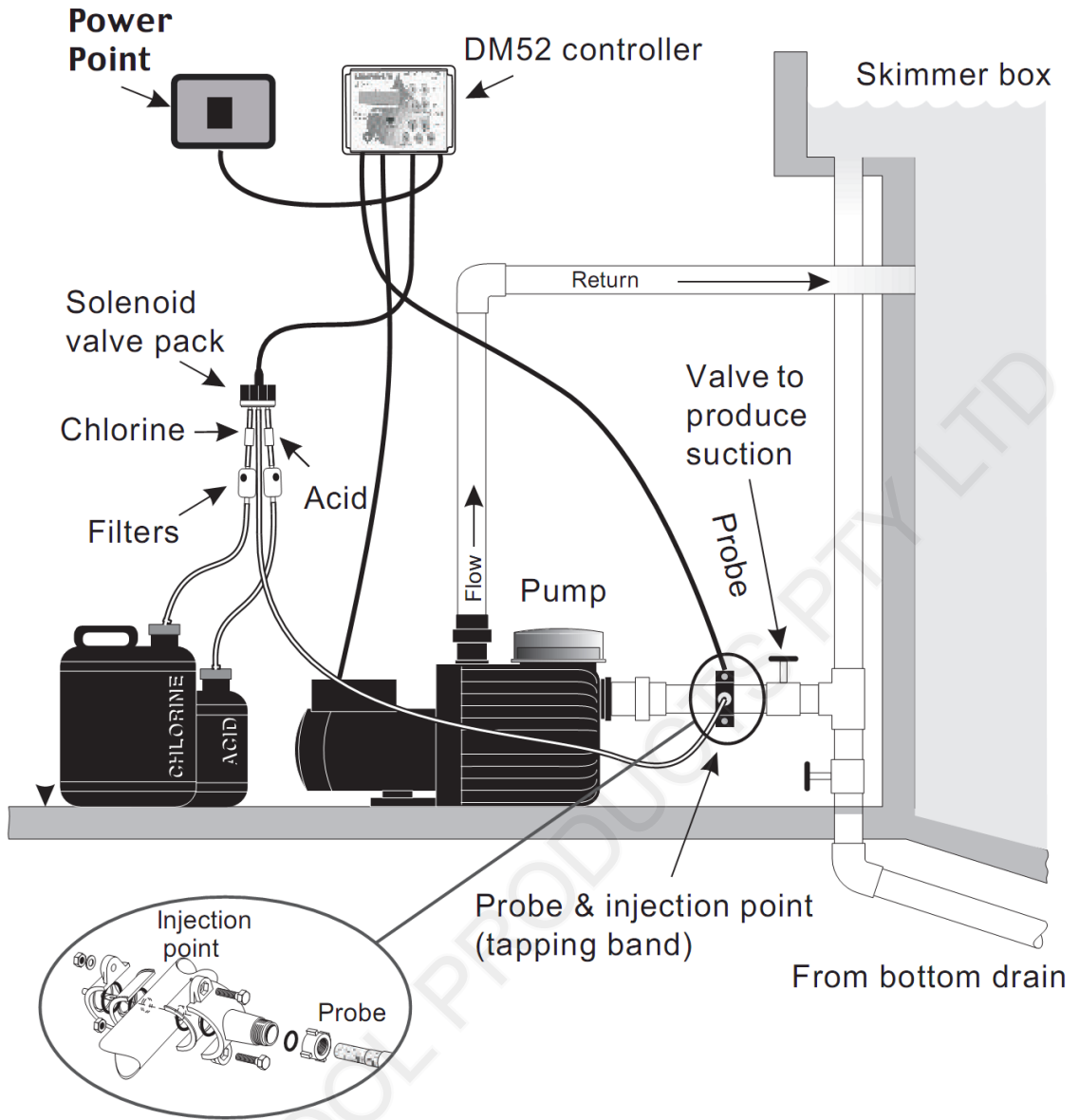

CHEMIGEM WHEN HEATER IS IN CIRCULATION, USING VENTURI INJECTOR DEVICE

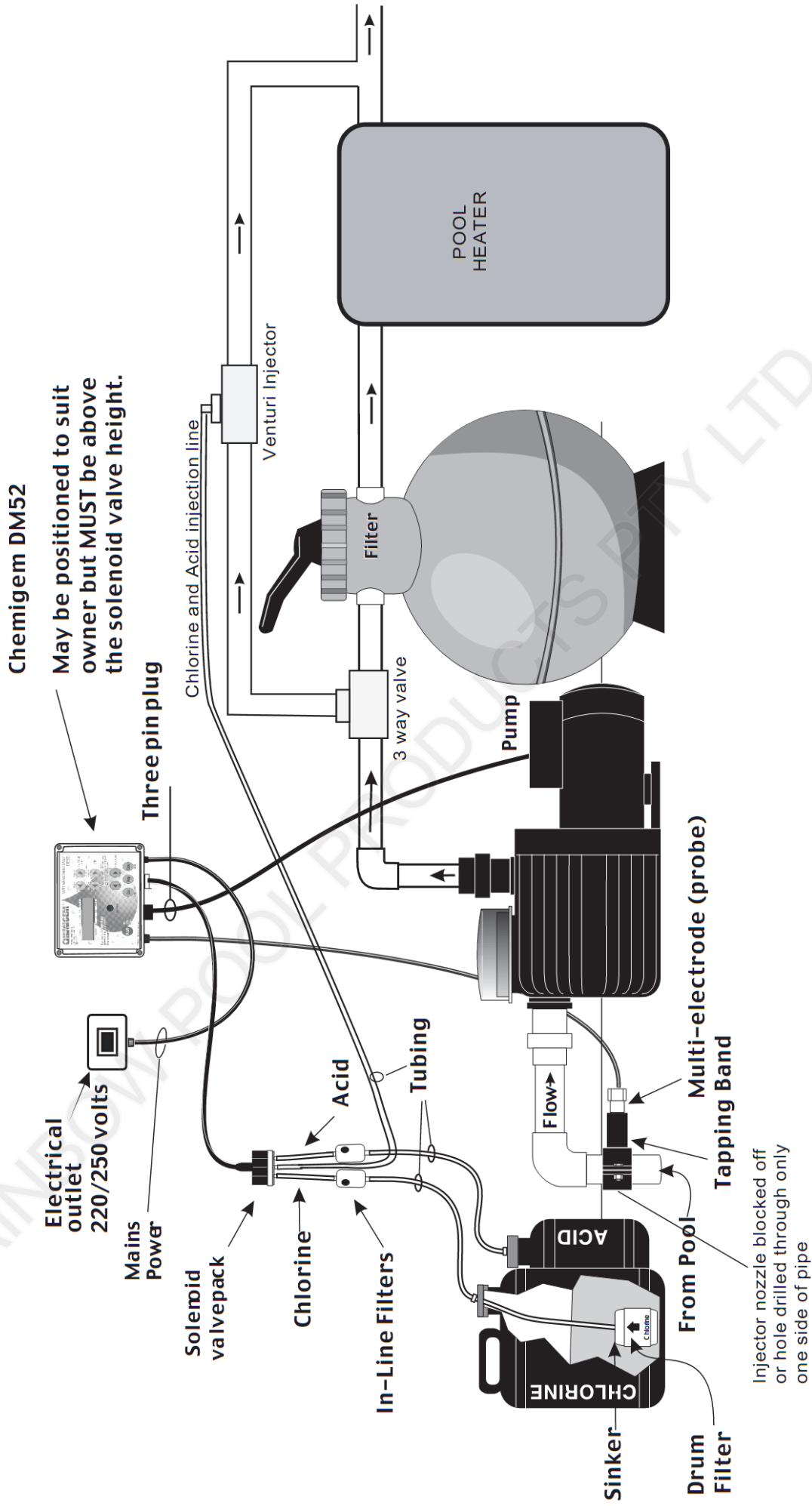

OPERATION

INTRODUCTION

The Chemigem is designed for use with all types of pools and to measure and automatically adjust the Chlorine and pH levels in the pool water.

Once levels are finally set or adjusted, the unit should be left alone.

The unit has been factory-set to achieve 650 millivolts Chlorine (ORP) and 7.7pH .

It has been found that if ORP is maintained at 650 millivolts, the kill time of E-coli type bacteria is about one second.

If the ORP is lowered to 550 millivolts, the same organisms could take up to 2 hours to be eliminated.

If the unit is used with these factory-set points as the selected levels, it should obtain approximately 2-4 ppm Chlorine and 7.7 pH, providing the stabilizer level is at 50 ppm. If the stabiliser level is 30 ppm or less, the Chlorine will be around 1 ppm.

READING THE DISPLAY PANEL

600	SET	650	CHLORINE (ORP)
7.2	SET	7.7	pH

What do the Chlorine and pH Numbers Represent?

The Chlorine (ORP) number is the activity of the chlorine (see explanation of ORP (Below) and measures in millivolts.

The pH number is the measure of acid / alkalinity and is displayed in units of the pH scale.

What is ORP?

The Chemigem is designed to measure and automatically adjust Chlorine (ORP) and pH levels in the pool water. (Refer above). As an explanation of what ORP is, the following is provided:

For over 20 years operators in many parts of the world have used Oxidation-Reduction-Potential (ORP or REDOX) values as a measure of Chlorine activity in water. ORP is a measure of the oxidising properties of the Chlorine in the water and is easily monitored by the Chemigem multi-electrode (probe).

When the multi-electrode (probe) is placed into water containing Chlorine it behaves like an electric cell and creates a small but measurable electric voltage. This voltage is proportional to the activity of Chlorine in the water.

It has been found that if ORP is maintained at 650 millivolts, the kill time of E-coli type bacteria is about one second. If the ORP is lowered to 550 millivolts, the same organisms could take up to 2 hours to be eliminated.

The test kit will measure Chlorine as parts per million (ppm) but the activity level of the Chlorine (and therefore the kill-time) depends upon the other materials dissolved in the pool water.

For an ORP controller to work properly the pH, Total Dissolved Solids (TDS), stabiliser (iso cyanuric acid) and calcium hardness must be maintained within the recommended levels.

Left Hand Side of Display Screen

The numbers on the left hand side of the display screen are the values the multi-electrode (probe) is registering for the actual levels of Chlorine and pH within the pool water.

The Chemigem will work to achieve the same values as those "SET" on the right-hand end of the display.

Right-Hand Side of Display Screen

The numbers on the right-hand side of the display screen are the values "SET". The unit has been factory-set to achieve 650 millivolts Chlorine (ORP) and 7.7pH as the preferred levels for Chlorine and pH respectively. These settings may be raised or lowered using the keypads No. 7 and 8 for pH and 9 and 0 for Chlorine (ORP) to the right of the display screen.

Password

The Chemigem is protected by a password No. 549

The number will only be required when operating any of the function changing keypads if the programme has been activated.

Alternative Display

The Chemigem is able to display the operation in pictorial form if preferred. To change to this form of display or to change back again, carry out the following steps:

With the unit running, obtain MAIN MENU by pressing keypad No. 4.

Press keypad No. 6 to move the flashing symbol over to NEXT

Press keypad No. 4

Press keypad No. 6 again to make DISP flash

Press keypad No. 4 once more

BEFORE STARTING THE CHEMIGEM

Before switching on the Chemigem carry out a full water test with a good quality test kit and balance the pool water to the levels shown below.

If the pool water is not balanced when the unit is first turned on, the unit may fail to correctly control the pool water.

Calcium Hardness, Total Alkalinity and pH should be adjusted first, followed by Chlorine and then Stabiliser (Iso-cyanuric acid).

Initial set up by the pool builder often includes the addition of the first amounts of chemicals. These may be estimated amounts and may require adjustment.

- Adding chemicals will take only a few minutes but removing the chemicals depends upon the natural dissipation from the pool, which could take weeks.
- pH is lowered by the addition of acid.
- Do not overdose the pool with Chlorine, pool Acid or Stabiliser.
- Always add the various pool chemicals slowly and with care, allowing sufficient time for complete dissolving and mixing throughout the pool water.
- Finally, carry out careful water tests to determine whether the correct amounts have been added.

If unsure how to carry out a water test and/or initially balance the pool water, request a qualified pool maintenance technician to do this for you.

It is suggested that swimming pool water should be maintained within the following ranges and that these ranges are confirmed with your local authorities as meeting their standards:

- CHLORINE 1.0 to 3.0 ppm or 3.0 mg/l
- pH 7.2 to 7.8
- CALCIUM HARDNESS 90 to 300 ppm or 300 mg/l
- STABILISER 30 to 50 ppm or 50 mg/l
- TOTAL ALKALINITY 80 to 300 ppm or 300 mg/l
- TOTAL DISSOLVED SOLIDS (TDS) 300 to 1500 ppm or 1500 mg/l

Pay particular attention to the instructions on the chemical drums. Add each chemical separately and slowly allowing plenty of time for them to dissolve. Always test between additions with a good quality test kit.

When diluting chemicals always add the concentrated chemical substance to the water and never add the water to the concentrated chemical. Some chemicals react violently with water and can splash into the face and eyes. **Always** wear a protective face shield and gloves for such operations.

After the pool water has been correctly balanced and the unit is switched on, it will measure and automatically adjust the Chlorine and pH levels. Chlorine and pool Acid will feed separately for a few seconds approximately every 3 minutes until the required levels are reached - depending on how the unit has been programmed.

ELECTRONIC CLOCK

The Chemigem has an in-built electronic clock with a battery back up (which should last for several years) that controls the automatic switching on and off of the pool pump.

DOSING OF CHEMICALS

Dosing of chemicals will only commence after a few minutes to allow for adequate mixing and accurate sensing. Similarly the safety warning sounds and alarm signals will not operate for the first 5 minutes. Every 3 minutes Chlorine will feed for 8 seconds and then pool Acid will feed separately for 7 seconds, until the required chemical levels are reached - depending on how the unit has been programmed.

Depending upon how the unit has been programmed, the standard procedure is that the first time that the unit operates it will take approximately 120 minutes to fully adjust to the required levels of Chlorine and pH. Thereafter it will normally restore the required levels in approximately 30 minutes. Ensure that the pool pump is running for a sufficient period to carry out these adjustments.

THE FIRST TWO WEEKS

The day following the installation of the Chemigem and after the pool pump has been running for 30 minutes, check the level of Chlorine and pH with a good quality test kit. If either of the levels is not exactly at the levels required, alter the settings a little. The unit will bring about the changes to the chemistry of the pool water as the pool pump circulates the water.

During the two weeks after a pool is first filled, the water chemistry will be settling down. It is likely that chemical levels will fluctuate during this time, so keep a check on the pool water with a good quality test kit or obtain confirmation by seeking help from a qualified pool maintenance technician.

It is not uncommon for new plaster/marblesheen pools to use more acid during their first month or two but do not let the pH and Total Alkalinity remain below recommended levels, or the lifetime of the pool surface may be shortened. Depending upon how the unit has been programmed, the standard procedure is that the first time that the unit operates it will take approximately 120 minutes to fully adjust to the required levels of Chlorine and pH. Thereafter it will normally restore the required levels in approximately 30 minutes.

Ensure that the pool pump is running for a sufficient period to carry out these adjustments.

If the actual chemical levels being achieved by the unit are not closely matching the “**SET**” levels, make minor adjustments (either up or down as the circumstances warrant) to the “**SET**” levels and re-test after 24 hours.

Additions by the unit are made in minutes, but removing excess chemicals may be difficult and require weeks.

Do not go outside the ranges given and pay attention to any specific requirements given by the pool builder.

Always take samples at a point near the skimmer box, for this is where the water is completely mixed giving the most accurate readings, never near the pool returns (eyeballs) where the water may have been freshly dosed by the unit.

Always follow the specific requirements of the pool builder when setting the chemical levels for the pool.

REGULAR CHECKS ON THE QUALITY OF POOL WATER

As a precautionary measure to ensure that the desired pool water chemical levels are being maintained and that the Chemigem is functioning correctly, regularly check the pool water quality with a good quality test kit.

If the pool is heavily used (such as in hot weather) it must be checked more frequently. As a general guide it is recommended that the check should be made at least twice weekly in the swimming season and once each two weeks in the non-swimming period. Seek guidance from your local authority or qualified pool maintenance technician.

REGULAR CHECKS OF THE SOLENOID VALVE TUBING

Regularly check the solenoid valve tubing to ensure that it has not become brittle.

If the solenoid valve tubing becomes brittle, it must be replaced immediately.

KEYPADS

KEYPAD No. 1:

“PUMP”

When the power has been switched on the screen will light up, however the pool pump will not operate unless the time is within a “**PUMP-ON**” period.

This keypad controls the operation of the pool pump and the controlling function of the unit. It has three positions and scrolls through them with each press on the keypad.

- The first press will move the pump status from “**AUTO**” to “**ON**” and the pool pump will then run for one hour. The screen will show a message to confirm this.
- Pressing the keypad again will move the pump status to “**OFF**” and the screen will confirm this.
- With a third press the pump status will return to “**AUTO**” and the timer will then switch the pump on and off according to the times set.

Dosing of chemicals will only commence after a few minutes to allow for adequate mixing and accurate monitoring. Similarly the safety warning sounds and alarm signals will not operate for the first 5 minutes.

Should a manual “**ON-TIME**” longer than 1 hour be required, proceed as follows:

- Press “**PUMP**” keypad No. 1 a few times until the screen message states that the pump is operating under “**AUTOMATIC TIMER**”
- Press once more and hold down continuously keypad No. 1 until the required “**ON-TIME**” in hours is displayed on the screen.

The unit will then operate for that number of hours and when all manually set times have expired the unit will automatically return to “**AUTOMATIC TIMER**” to switch on and off the pool pump.

If the Chemigem inbuilt pool pump timer is disabled by the pool operator, the unit will lose the ability to turn the pool pump on manually with the “PUMP” keypad. To turn the pool pump on or off manually when the timer has been disabled, use the mains power switch.

To reinstate the inbuilt timer, set “**AUTOMATIC PUMP TIMES**”

KEYPAD No. 2:

“ESCAPE” AND “ALARM MUTE”

The keypad has three functions: -

- When the setup of the Chemigem is completed or required changes made, pressing the **ESC** keypad will return to normal display.
- When alarms are sounding it can be pressed to mute the warning tone. The warning tone will be restored when the unit next switches on.
- The flashing red light remains on until the pool chemistry returns to the preset levels.
- Removes lock-out associated with high pH alarm.

KEYPAD No. 3:

“HELP”

When the Chemigem is indicating that the chemical levels in the pool water are incorrect, helpful advice is obtained by pressing this keypad. Suggestions and guides are given. Reference to the relevant pages in this manual provide a more in-depth treatment of the problems.

KEYPAD No. 4:

“ENTER”

The main feature of the keypad is to obtain the menu items and to select those that are made to flash.

- Pressing this keypad brings the **“MAIN MENU”** items on to the screen
- It will select any word that is flashing on the screen. To change the word that is flashing, use the keypads No'd 5 or 6, then press keypad No. 4 again to select it.

It also advances the digits when setting the clock and timer. When adjusting times in the **“CLOCK”** or **“TIMER”** functions, each press of the **ENTER** keypad advances the number which is flashing, by one digit.

KEYPAD No. 5:

“CHLORINE MANUAL FEED”

If as a result of a pool water test it is determined that the Chlorine is not within acceptable levels, the Chemigem can perform a manual dosing operation to bring the level up rapidly.

The unit is equipped with the facility to override its normal operation and to dose Chlorine manually. Keypad No. 5 performs this function. Refer also to keypad No.6 that manually feeds pool Acid (pH). Normally it will only be necessary to manually dose either Chlorine or pH, however if for any reason keyboards No. 5 and 6 are both pressed at once, only the pH will operate.

As soon as the manual-feed keypad is pressed the main screen will appear blank for 2 seconds after which it will display which feed is taking place. Feeding will continue for about 20 seconds, while the keypad is pressed. When the display panel returns to normal the dosing stops. Press again to repeat as many times as required. After manually dosing with Chlorine, monitor the setting for several hours afterwards to make sure that the recommended levels have been restored.

KEYPAD No. 6:

“POOL ACID MANUAL FEED”

If as a result of a pool water test it is determined that the Pool Acid (pH) is not within acceptable levels, the Chemigem can perform a manual dosing operation to lower the level rapidly.

The unit is equipped with the facility to override its normal operation and to dose pool Acid manually.

Refer also to keypad No. 5 that manually feeds Chlorine. Normally it will only be necessary to manually dose either Chlorine or pool Acid, however if for any reason keypads No. 5 and 6 are both pressed at once, only the pool Acid will operate.

As soon as the manual-feed keypad is pressed the main screen will appear blank for 2 seconds after which it will display which feed is taking place. Feeding will continue for about 20 seconds, while the keypad is pressed.

KEYPADS No. 7 and 8:

“AUTOMATICALLY INCREASE AND DECREASE POOL ACID SET LEVELS”

Keypads No. 7 and 8 are used to set the level of pH required in the pool water. The keypads raise or lower the required level and the unit will then acquire and hold the set level. If the pH level required is lowered using keypad 7 the unit will achieve the new level quickly by adding some pool Acid.

However if the pH level required is raised using keypad 8, the unit cannot make the changes rapidly. (If Chlorine is added to the pool water during the next few weeks it will slowly raise the pH of the pool water) These two keypads are also used together to turn the pH function on and off.

KEYPADS No. 9 and 0:

“AUTOMATICALLY INCREASE AND DECREASE CHLORINE SET LEVELS”

Keypads No. 9 and 0 are used to set the level of Chlorine required in the pool water. The keypads raise or lower the required level and the Chemigem will then acquire and hold the set level.

If the Chlorine level required is to be lowered, keypad 9 will lower the set level. It may take some days or even weeks before the Chlorine level drops to the required setting. However if the Chlorine level is to be raised, press keypad 0. The unit will feed Chlorine every 3 minutes until the set level is reached.

EMPTYING SWIMMING POOL AND FREEZING CONDITIONS

- If the pool water is emptied from the swimming pool, pool pump, pool filter and associated pool piping for any reason (such as when the pool is being serviced)
- During periods of freezing conditions (below 32 degrees fahrenheit or zero degrees celsius)

It is essential to remove the multi-electrode (probe) and to cover the sensing end of the multi-electrode (probe) with the white protective cap that is provided and to temporarily seal the resultant exposed hole in the tapping band (to avoid water seepage or sand and dirt entering the poolpiping).

Failure to carry out these functions may damage the multi-electrode (probe) and negate the Warranty.

Contact the supplier of the Chemigem or a qualified pool maintenance technician if assistance is required for the removal and re-installation procedures.

TURNING ON AND OFF THE CHLORINE AND POOL ACID

Do not turn off either the Chlorine or pool Acid supply without advice from a qualified pool maintenance technician or the supplier of the Chemigem.

Turning off the supply of either of the chemicals is not normally necessary and could lead to unbalanced pool water that may not be safe for swimming.

In the event that it is necessary to turn off (disable) the Chlorine or pH function, the Chemigem has an easy means of doing this:

To Turn Off the Chlorine

Press and hold down the keypads No. 9 and 0 at the same time for 3 seconds. While doing so the display will show **“TO DISABLE CHLORINE HOLD FOR 3 SEC”** and at the end of the 3 seconds it will display **“CHLORINE OFF”**.

To Turn On the Chlorine

Press and hold down keypads No. 9 and 0 at the same time for 3 seconds, after which time the unit will beep and resume displaying the set and actual values for the Chlorine (ORP) of the pool.

To Turn Off the Pool Acid (pH)

Press and hold down the keypads No. 7 and 8 at the same time for 3 seconds. While doing so the display will show **"TO DISABLE pH HOLD FOR 3 SEC"** and at the end of the 3 seconds it will display **"pH OFF"**.

To Turn On the Pool Acid (pH)

Press and hold down keypads No. 7 and 8 at the same time for 3 seconds, after which time the unit will beep and resume displaying the set and actual values for the pH of the pool.

MANUAL DOSING OVERRIDE

If as a result of a pool water test it is determined that the Chlorine and/or pH are not within acceptable levels, the Chemigem can perform a manual dosing operation to rapidly add Chlorine and pool Acid.

Keypads No. 5 and 6 carry out this function. Normally it will only be necessary to have to dose one of the chemicals in this fashion but if for any reason both of these keypads are pressed at once, only the pH will operate.

As soon as the manual-feed keypad is pressed the main screen will appear blank for 2 seconds after which it will display which feed is taking place. Feeding will continue for about 20 seconds, while the keypad is pressed. When the display panel returns to normal, the dosing stops. Press again to repeat as many times as required.

RE-CALIBRATING pH

The Chemigem has been equipped with a quick procedure to re-calibrate pH values. If for any reason the factory-settings are not the required levels, the unit can be recalibrated. Do not re-calibrate until identical pH readings have been obtained from at least three test kit results from around the pool.

Steps to take once an accurate value of the pool pH has been obtained: -

- Obtain **MAIN MENU** by pressing the **ENTER** keypad
- Press keypad No. 6 to make **"NEXT"** flash, then press **ENTER** again
- With **"CALIB"** flashing press **ENTER** again
- Enter the value of the pool pH by pressing keypads No'd 7 or 8 to obtain the correct value
- To activate this new value press both **HELP** and **ENTER** keypads together (keypads No'd 3 and 4)

Instructions similar to above will appear on the screen and will scroll after 5 seconds.

RE-CALIBRATING CHLORINE

Recalibrating Chlorine(ORP) is not needed and it should not be actioned without the prior advice of Pool Controls.

POOL PUMP TIMER

SETTING THE INBUILT POOL PUMP TIMER

The unit's built-in pump timer is factory set to two ON TIMES each day. If the built-in pump timer is not to be used (because an external pump timer is used), the built-in pump timer must be permanently turned off. (Refer below) If it is decided to turn off the automatic pool pump timer and use the manual switching of the pool pump on a daily basis, this may result in unbalanced pool water that is not safe for swimming. If necessary, obtain advice from a qualified pool maintenance technician.

TO TURN OFF THE INBUILT POOL PUMP TIMER

It can be switched off as follows: -

- Press the **ENTER** keypad No. 4 to display **MAIN MENU**.
- Select flashing word **TIMER** by pressing **the ENTER** keypad.
- Keeping in **PROG 1** and using keypad No. 6, move the flashing symbol to the right and advance all the numbers to zeros by pressing **ENTER** as many times as required.
- Return to normal display by pressing the **ESC** keypad several times.

IF THE INBUILT POOL PUMP TIMER IS DISABLED

If the in-built timer is disabled, the Chemigem will lose the ability to turn the pool pump on manually with the "**PUMP**" keypad. To turn the pool pump and the Chemigem on or off manually, it will be necessary to use the mains power switch.

To reinstate the inbuilt pool pump timer set "**AUTOMATIC**" **PUMP TIMES** (Refer to page 23)

MANUAL STARTING OF THE INBUILT POOL PUMP TIMER

It is likely that the pool water balance will fluctuate during any period when the pool pump is manually started and stopped, for it may be that the pool pump will not be running on a regular basis for the required times.

During this period it is strongly advisable to regularly check on the pool water with a good quality test kit.

To turn the Chemigem on when the timers are already programmed and functional, but when it is not in a pumping cycle, press the keypad marked **PUMP** (keypad No.1). The first press will bring the pool pump and the unit on for one hour.

Manual "**ON-TIMES**" is switched off by pressing the pump keypad once (goes to "**MANUAL OFF**") or twice (goes to "**AUTO**").

Should a manual "**ON-TIME**" longer than 1 hour be required, proceed as follows: -

- Press keypad No. 1 a few times until the screen message states that the pump is operating under "**AUTOMATIC TIMER**".
- Press once more and hold down continuously (keypad No.1) until the required "**ON-TIME**" in hours is displayed on the screen.

The Chemigem will then operate for that number of hours and when all manually set times have expired the unit will automatically return to "**AUTOMATIC TIMER**" to switch on and off the pool pump.

SETTING "AUTOMATIC" POOL PUMP TIMES

Utilising the automatic pool pump timer provides an assured method of achieving a regular circulation of pool water through the pool filter. Further, as the Chemigem operates when the pool pump is running, the pool water will automatically remain balanced.

Factory set times vary depending on State.

The electronic timer is purely a 24 hour device and **ON TIMES** cannot be greater in value than **OFF TIMES**.

The timer can be programmed to operate at the most convenient times during the day and can easily be changed to suit varying pool usage at different times of the year.

- Pump timing is a function of the **MAIN MENU** that is accessed by pressing keypad No. 4 labeled **ENTER**. Once the **MAIN MENU** is displayed on the screen, follow these steps:
- The word **TIMER** will be flashing and it must be selected from the menu by pressing **ENTER** keypad No. 4.
- The first timing program will be displayed with **PROG 1** flashing. To select others from the seven programs available, press **ENTER** while **PROG 1** is flashing, to advance to program 2, 3 etc.
- The **START** and **STOP** times are shown as two pairs of digits. The first pair in each case being hours, the second pair being minutes. The 24-hour clock is used. To select the **START TIME HOURS** move the flashing symbol to the right by pressing keypad No. 6. The **HOURS** digits will now be flashing. To increase the **HOURS** press the **ENTER** keypad once for every hour the start time is to be advanced. If advanced too far, keep advancing until the display is returned to the required number
- To select the **START TIME MINUTES** move the flashing symbol to the right again, using keypad No. 6 as stated above and advance the minutes by 5 minutes for each press using the **ENTER** keypad
- Set the **STOP TIMES** by moving the flashing symbol further to the right with keypad No. 6. Select it by pressing **ENTER**, and advance the hours as before with the **ENTER** keypad. Complete by setting stop time minutes if required. If other start and stop times are required, select **TIMER** and then **PROG 2** etc. and program start and stop times as required
- Press **ESC** keypad several times to return to normal display.

TO SET THE CLOCK

A 24 hour clock is used

- Select **MAIN MENU** by pressing **ENTER** (keypad No. 4)
- Make the word **CLOCK** flash by pressing keypad No. 6
- Select **CLOCK** by pressing keypad No. 4
- The first two digits will be flashing. These are the hours that can be advanced by one hour for each press of keypad No. 4
- Move the flashing point to the right again using keypad No.6 and advance the minutes to the correct time using keypad No. 4
- Press **ESC** several times to return to normal display

ALARMS

INDICATOR LIGHT AND SOUND

The safety warning sounds and alarm signals will not operate for the first 5 minutes.

THE NORMAL RANGE

When the pool pump is running the Chemigem shows a green light if the pool chemical levels are within the normal range. To ensure the unit is maintaining the pool water at the required levels, check the pool water on a regular basis with a good quality test kit.

The unit operates to keep the activity of Chlorine in the pool at a level where microorganisms are killed in about 1 second. For this to happen both the Chlorine (ORP) and pH must be kept within a fairly narrow band. (Refer to page 15)

OUTSIDE THE NORMAL RANGE

If the levels of chemicals move outside the optimum band the Chemigem will indicate this in two ways.

- It will sound an alarm (provided the alarm is switched on: (Refer to “Audible Alarm” on page 25)
- The red light will flash at one-second intervals

When the alarm is sounding and the red light is flashing the unit will also indicate on the screen the reason for the alarm.

This booklet contains sections on what remedial action to take should the warnings operate.

Pressing the HELP keypad will also provide immediate suggestions. If the unit is indicating that the chemical levels are outside the normal range do not use the pool for bathing unless the problem is resolved. Study the Problem Solving guide on pages 34 to 36. Failure to take these safety precautions when the unit is indicating it is outside normal ranges may be dangerous, as outlined below: -

- Low Chlorine means the water could be carrying live and dangerous germs
- High Chlorine will bleach swimwear and may irritate sensitive skin
- Low pH is acidic and may irritate eyes and skin
- High pH makes the Chlorine less able to kill germs

THE AUDIBLE ALARM

The alarm sound can be turned down in volume or completely off if required. It may be temporarily muted by pressing keypad No. 2, leaving the red warning light flashing and the screen message to indicate the warning state. However, the next time the pump turns on it will restore the warning sound unless the pool chemistry has been brought back into the normal range.

If it is decided to turn off the audible alarm for any reason, the Chemigem will not have that warning capability and the pool owners will have to rely on their own ability to monitor the indicator lights on the face of the unit to verify that the Chlorine and pH levels are within acceptable limits (Refer to pages 14&15)

To lower the volume to half level or turn the sound permanently off, proceed as follows-

- Obtain **MAIN MENU** by pressing the **ENTER** keypad
- Press keypad No. 6 to make **NEXT** flash then **ENTER**
- Press keypad No. 6 to make **SECUR** flash then **ENTER**
- Press keypad No. 6 to make **SYS** flash then **ENTER**
- Press **ENTER** repeatedly to get required option
- Press **ESC** several times to return to normal display

ALARM LIGHT AND SOUND - STEPS TO TAKE

Alarms must not be ignored. Immediately investigate the causes and until it is certain that the pool water is safe, do not use the pool. Seek professional help from a qualified pool maintenance technician if it is not fully understood what is happening.

- Read the message on the screen. This will advise which chemical is out of the normal range
- Make a test of the pool water with a good quality test kit to check if the Chemigem has the same readings
- It is very important that the chemical reagents in the test kit are well within their use-by date. If in doubt, take a fresh sample of pool water to a pool shop for an independent test
- If the Chlorine is too low, or the pH too high, check the drums of chemical to determine whether they have run out
- If the Chlorine is too high or the pH too low, switch off the one that is incorrect and as an extra precaution, remove the tube from the drum and place it in a bucket of water

Consult the Problem Solving section on pages 29 to 30 for suggestions on how to deal with chemical excesses.

CHEMICALS

CHEMICAL FEEDING

Depending upon how the unit has been programmed, the standard procedure is that the first time that the unit operates it will take approximately 120 minutes to fully adjust to the required levels of Chlorine and pH. Thereafter it will normally restore the required levels in approximately 30 minutes.

Ensure that the pool pump is running for a sufficient period to carry out these adjustments.

ADJUSTMENTS TO CHEMICAL LEVELS

The day following the installation of the Chemigem and after the pool pump has been running for 30 minutes, check the level of Chlorine and pH with a good quality test kit. If either of the levels is not exactly at the levels required, alter the settings a little with keypads No'd 7 and 8 or 9 and 0. The Chemigem will bring about the changes to the chemistry of the pool water as the pool pump circulates the water. It is suggested that swimming pool water should be maintained within the following ranges and that these ranges are confirmed with your local authorities as meeting their standards:

- CHLORINE 1.0 to 3.0 ppm or 3.0 mg/l
- pH 7.2 to 7.8
- CALCIUM HARDNESS 90 to 300 ppm or 300 mg/l
- STABILISER 30 to 50 ppm or 50 mg/l
- TOTAL ALKALINITY 80 to 300 ppm or 300 mg/l
- TOTAL DISSOLVED SOLIDS (TDS) 300 to 1500 ppm or 1500 mg/l

The Chemigem will work at maintaining Chlorine (ORP) levels within a range of 600 - 700 millivolts when set at 650 and pH levels within 0.2 pH units of that set.

It has been found that if ORP is maintained at 650 millivolts, the kill time of E-coli type bacteria is about one second.

If the ORP is lowered to 550 millivolts, the same organisms could take up to 2 hours to be eliminated.

The pH scale runs from 1 to 14, with 1 being strongly acid and 14 being strongly alkali.

Pool water should be between pH 7.0 and 7.8 (which is almost neutral) so it is not harmful to humans.

pH values at the upper and lower ends of this scale are **very dangerous**.

pH is also very important in keeping pool surfaces from degrading too rapidly. Too much acid (too low a pH value) will cause plaster surfaces to degrade quickly. The unit is factory - set to help maintain pH at 7.7 to keep the pool plaster in good condition. If after a few days the unit is not able to keep within these ranges, consult the Problem Solving pages 34 to 36 in this manual and/or contact the supplier of the Chemigem or a qualified pool maintenance technician.

IMPORTANT POINTS TO NOTE

- Adding chemicals will take only a few minutes but removing the chemicals depends upon the natural dissipation from the pool water, which could take weeks
- Add pool chemicals slowly and with appropriate care, allowing sufficient time for complete dissolving and mixing throughout the pool water and then carry out water tests to determine whether the correct amounts have been added
- Take samples at a point near the skimmer box, for this is where the water is completely mixed, giving the most accurate readings. Never take samples near the pool returns (eyeballs) where the Chemigem may have freshly dosed the pool water
- Do not overdose the pool water with either Chlorine, pool Acid or Stabiliser
- pH is lowered by the addition of pool Acid
- Excess pool Acid (low pH) is neutralised with Sodium Carbonate (strong) or Sodium Bicarbonate (less strong)
- Excess Chlorine is neutralised with Sodium Thiosulphate
- Excess Alkalinity is neutralised with Hydrochloric acid (Muriatic acid)

POOL CHEMICAL DILUTIONS

Pool Acid

The Chemigem is designed to automatically help keep the correct level of pH (and Chlorine) in pool water by continuously monitoring the water chemistry while the pool pump is operating. Pool Acid (and Chlorine) is dosed into the pool water as and when necessary.

There are two kinds of pool Acid in common use and the unit is able to use both:

- Hydrochloric Acid (muriatic acid).
- Non-Fuming Pool Acid (dilute sulphuric acid)

It is strongly recommended that the non-fuming pool Acid be used because the Hydrochloric acid gives off corrosive and highly irritating fumes in its concentrated form. It must be kept at least 6 feet from the unit unless diluted at least 5 to 1 with water.

Diluting Pool Acid is strongly recommended as follows:

- Pools larger than 90,000 litres 15 litre drum, full strength
- 50,000 to 90,000 litres 15 litres diluted 1:5 with water
- 10,000 to 50,000 litres 15 litres diluted 1:10 with water
- Spas/pools 2,000 to 10,000 litres 15 litres diluted 1:15 with water
- Spas less than 2,000 litres 15 litres diluted 1:20 with water

IMPORTANT Always add concentrated Acid to the water not the water to the concentrated Acid. Small quantities of water will react violently with concentrated Acid, giving off heat and boiling the water that may splash Acid.

Chlorine

The Chemigem is designed to automatically help keep the correct level of Chlorine (and pH) in pool water by continuously monitoring the water chemistry while the pool pump is operating. Chlorine (and pool Acid) is dosed into the pool water as and when necessary.

The Chlorine in common use is a sodium hypochlorite solution. The Chemigem uses this chemical.

Diluting Chlorine is strongly recommended as follows:

- Pools larger than 90,000 litres 20 litre drum or larger
- 20,000 to 90,000 litres 20 litre drum
- 10,000 to 20,000 litres 20 litres diluted 1:1 with water
- Spas/pools 2,000 to 10,000 litres 20 litres diluted 1:15 with water
- Spas less than 2,000 litres 10 litres diluted 1:20 with water

RAINBOW POOL PRODUCTS PTY LTD

PROBLEM SOLVING

LOW CHLORINE ALARM

This indicates that the Chlorine level in the pool water is considerably lower than the level that was set.

The Chemigem will restore the level by feeding Chlorine approximately every 3 minutes until the set level is reached again (however feeding may be inhibited by one of the factors listed below). As the Chlorine level in the water approaches the set level, the warning sound and the red warning light will switch off, but the warning sound may be switched off at any time by pressing the ESC keypad No.2. This sound will come on again the next time the pool pump operates if the Chlorine level is still too low.

Low Chlorine levels could be due to the following:

- Excessive bather load
- The Chlorine drum is empty
- Increasing the set level by a large amount
- The filter has been off for a long period on a hot day
- The Stabiliser level is too low
- The pH is too high
- The filter requires backwashing
- The strainer (part of the pump) requires cleaning out.
- Inadequate pool water circulation
- The injector nozzle in the tapping band is clogged
- The venturi system (if fitted) is clogged
- A faulty solenoid valve
- Multi-electrode (probe) requires cleaning (Refer to page 30)

HIGH CHLORINE ALARM

This indicates that the Chlorine level in the pool is considerably higher than that which was set. Should this be due to an intentional overdose (super chlorination or shock treatment) it may be some days or even weeks before the level drops and the warnings turn off.

High Chlorine levels could be due to the following:

- Manual overdosing with Chlorine
- The pH is too low (too much pool Acid)
- Changing the set level to a much lower setting
- High total dissolved Solids (TDS) level (above 2000 ppm)
- Inadequate pool circulation
- The solenoid valve is faulty
- Multi-electrode (probe) requires cleaning (Refer to page 35)

LOW pH ALARM (Excess Acid)

This indicates that the pH level in the water is considerably lower than that which was set. The Chemigem cannot do anything about this condition except warn about it. However as a safeguard, the unit operates a lock on any more additions of Acid (that would only make matters worse) until the pH is brought back into the normal range with the addition of some Sodium Carbonate or Sodium Bicarbonate.

Low pH levels could be due to the following:

- Manual overdosing with pool Acid
- Poor pool water circulation leading to over-dosing.
- Excessive rainfall (that is slightly acidic) neutralising the alkalinity of the pool.
- A faulty solenoid valve.
- Multi-electrode (probe) requires cleaning (Refer to Cleaning Instructions below)

HIGH pH ALARM (Insufficient Acid)

This indicates that the pH level in the water is considerably higher than that which was set. In this case the Chemigem will be in a locked condition and will not dose further pool Acid until the lock mechanism is overridden. This is carried out by pressing the **ESC** keypad No.2. The unit will then dose further pool Acid until the level for pH that was set has been reached.

High pH levels could be due to the following:

- Initial conditions in a new plaster lined pool being very alkaline and overwhelming the unit's ability to dose sufficient acid.
- The unit has a proportional acid setting that may have been adjusted to add insufficient acid
- The Acid drum may be empty
- Super chlorinating the pool
- The injector nozzle in the tapping band is clogged
- The venturi system (if fitted) is clogged
- A faulty solenoid valve
- The filter needs backwashing
- Multi-electrode (probe) requires cleaning (Refer to Cleaning Instructions below)

CLEANING THE MULTI-ELECTRODE (PROBE)

- Remove from the tapping band by unscrewing the retaining nut and pulling out the multi-electrode (probe)
- Holding the cable, gently swirl the multi-electrode (probe) sensing components in a dilute solution of Hydrochloric Acid for 30 seconds.
- Rinse the multi-electrode (probe) in clean water
- Replace the multi-electrode (probe), making sure the "O" seal is in place
- Screw up the nut with fingers only. (Refer to page 10)

PROBLEM SOLVING FLOW CHART

