

Robotic Pool Cleaner with Top Access

Operating Instructions



Rainbow Pool Products

PO Box 2388, Mansfield Qld 4122

Telephone STD 61-7-3849 5385

Facsimile STD 61-7-3849 5384

Email: info@rainbowpoolproducts.com.au

Web: www.rainbowpoolproducts.com.au

Product 11710

Product Inst 319



Quality Pool & Spa Products

IMPORTANT SAFETY INSTRUCTIONS

READ AND FOLLOW ALL THE INSTRUCTIONS

CAUTION: Do not plug the power supply into a grounded outlet or do not switch the pool cleaner "ON" if it is not fully immersed in water. Operating the cleaner out of water will cause severe damage immediately and will result in loss of warranty.

Allow the cleaner to remain in the pool for 15 to 20 minutes following the end of its cleaning cycle. This will allow the motors to cool adequately. Do not leave the cleaner in the pool all the time. Always remember to turn the power supply "OFF" and unplug it from the power outlet before removing the cleaner from the pool.

WARNING: The cleaner must not be used when people are in the water. For use with swimming pool only

Safety Note

- The unit must be supplied through a residual current device (RCD) having a rated residual operating current not exceeding 30 mA
- The connection to the branch circuit should be consistent with the local and national wiring rules (electrical code).
- Mishandling of the unit can result in leakage of lubricants.
- If the supply cord is damaged, it must be replaced by the manufacturer's service agent or a qualified and trained person in order to avoid hazards.



This appliance is not intended for use by persons (including children) with reduced physical, sensory or mental capabilities, or lack of experience and knowledge, unless they have been given supervision or instruction concerning use of the appliance by a person responsible for their safety. Children should be supervised to ensure that they do not play with the appliance.



WARNING: A Ground Fault Current Interrupter (GFCI-USA) or a Residual Current Device (RCD-EUROPE) must be installed to protect your electric outlet and prevent any possible electric shock.

SAVE THESE INSTRUCTIONS

Dear Customer,
Thank you for choosing our product to clean your pool. We hope that you will enjoy using your new robot to maintain your swimming pool for years to come.
Before you begin to use your robot, please take a few minutes to carefully read these operating instructions.
Again, thank you for choosing our product.

Components

While the appearance of your cleaner and some of its components may differ from those shown here, the function of the cleaner, operating procedures and maintenance practices are the same.

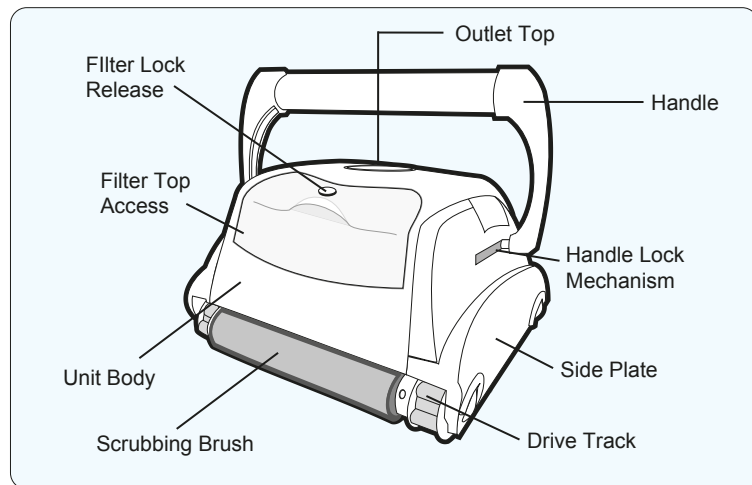

Your new automatic pool cleaner contains:

- The robotic pool cleaner with its floating cable.
- The Power Supply (transformer).

Please read this manual completely before operating your pool cleaner.

Operating the pool cleaner

1. Place the power supply (transformer) at least 3.6 meters / 11.8 feet from the pool and at least 12 cm / 4 inch above the surface (fig.1). The transformer will supply low voltage to the cleaner.
2. Uncoil the cable.(fig.1a)

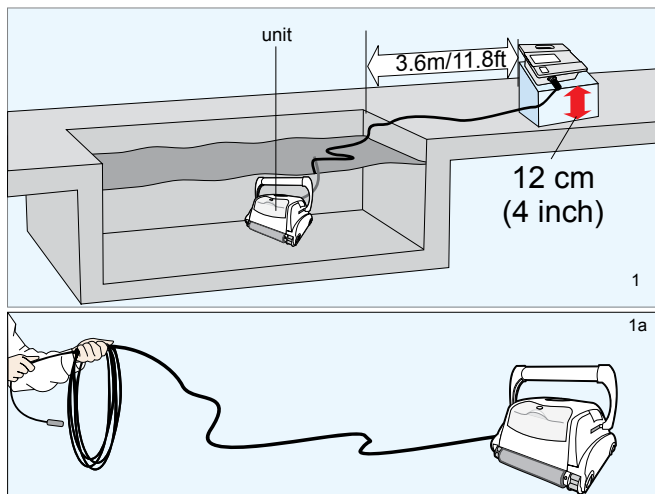

3. **ONLY FOR MODELS WITH FLOATING HANDLE** - For proper operation, lock the moveable handle diagonally across the top of the cleaner's body. Push down on the **handle lock** mechanism and slide the handle all the way to the end, then release the lock. Depending on your model, the handle **lock button** might be **vertical or horizontal** (fig.2a, 2b). The handle will remain fixed in this position. Repeat this process on the other side of the cleaner. Remember, the handle must be fixed diagonally (fig.2c)

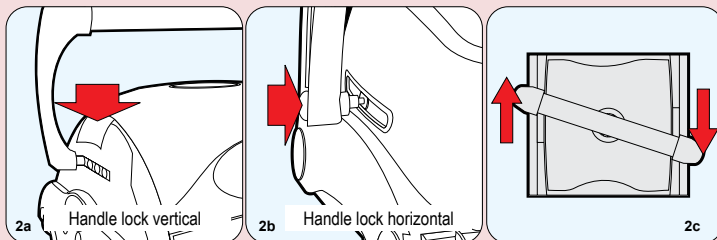

4. Place the unit in the water. Turn the unit side to side in the water to allow air to escape from the body and then let the cleaner sink to the bottom of the pool (fig.3). Then, spread the cable over the surface of the pool as evenly as possible (fig.1).



5. Plug the cable into the power supply. Make sure the key on the plug corresponds exactly with the key slot on the socket of the power supply (fig.3a). Plug the power supply into a grounded outlet. Ensure that the electric outlet has been properly grounded (fig.3b). The light will glow indicating that the system is "ON" and the pool cleaner will start the cleaning cycle. The unit keeps record of the number of cleaning cycles. Only an authorized service center can display the accumulated cleaning cycles. (See details on the next page)

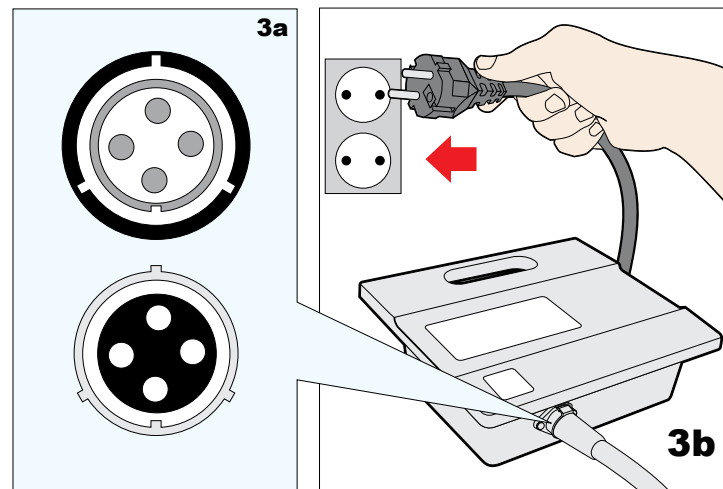

Operating the pool cleaner

Plugs Type I

To plug the cable (Fig A) into the socket on the power supply (Fig. B), please do the following:

1. Prepare the plug as seen in (Fig. C) with the key and 3 outside slots exactly as shown.
2. Fit exactly the key and the slots from cable plug with the corresponding key and slots from the power supply socket. (Fig. D)
3. Push the plug into the socket of the power supply all the way in.
4. Once the plug is in, rotate the plug to the right to lock it into place (Fig. E).
5. To remove the plug, first rotate the plug to the left to unlock it, then pull it out (Fig. F).

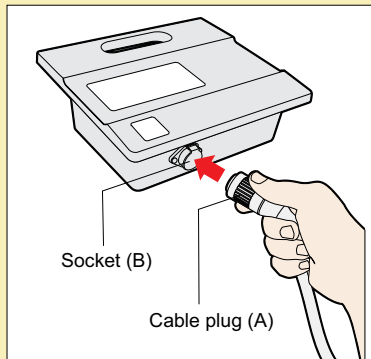
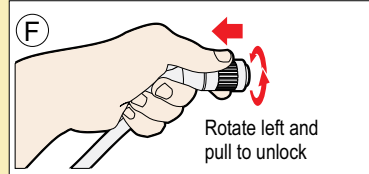
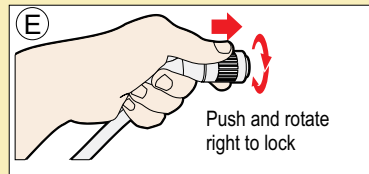
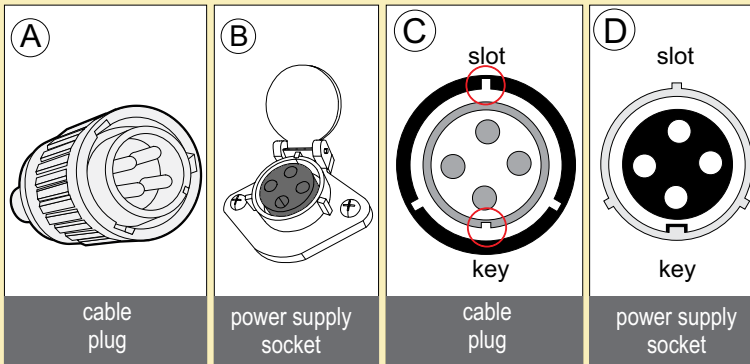

Grounding

The power supply must be connected to a grounded 3 conductor socket. The mains power supply must be connected via a GFCI (ground fault circuit interrupter) or RCD (residual current device) having a rated residual operating current not greater than 30mA.

Fuse

The fuse must be changed by an authorized service agent or trained and qualified person only. For continued protection against risk of fire, replace only with the same type and rating of fuse.

Maintenance and safety

The cover should not be removed except by an authorized service agent or trained and qualified person. No internal adjustment or component replacement can be carried out by the user. The power cable must be disconnected before removing the cover.

If the power supply cord is damaged, it must be replaced by an authorized service agent or trained and qualified person. Do not operate the supply if the cord is damaged.

Environmental conditions

The power supply is designed to work both indoors and outdoors. However, the unit should not be operated in direct sunlight or be exposed to water. The power supply should not be operated in an ambient temperature in excess of 40°C.

Physical

Dimensions (W * D * H) _____ 273mm * 242mm * 90mm

Weight _____ 1.9 Kg

Electrical

Input rating _____ 100-240V~, 50/60Hz, 210W

Output rating _____ 29V ,6.3A.

Storage temperature _____ -10° C - 60° C

Operating temperature _____ 0° C - 45° C

Ingress protection _____ IP54

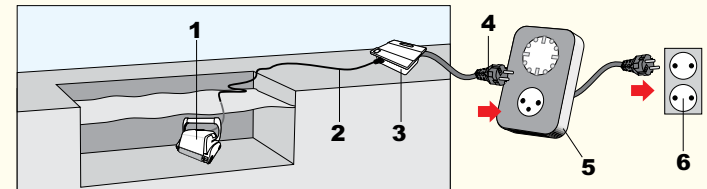

External Timer Capability

This feature will enable the end user to program the cleaning schedule through an external timer (sold separately).

1. Unit
2. Cable
3. Power supply
4. Power supply plug
5. External timer
6. Outlet

Operating the pool cleaner

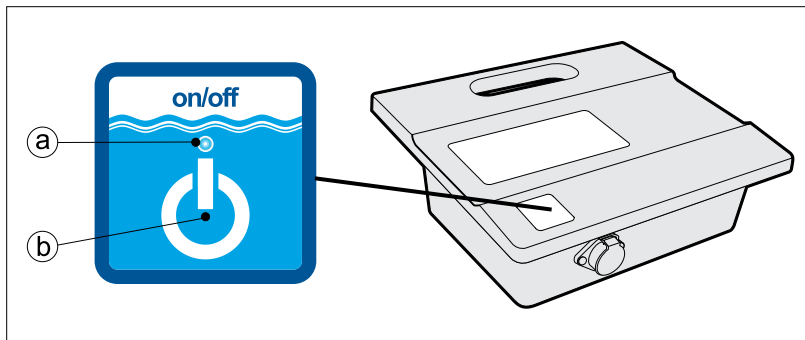

a. Power LED

The blue LED flashes when the power supply is in standby mode and lights continuously when the pool cleaner is operating. The power button switches between ON and STANDBY

b. "POWER" button

The button switches between "ON" and "STANDBY".

IMPORTANT- After every cycle the pool cleaner will automatically go to "standby". In case you want to turn the machine off during the working cycle, press the "power" button once and the LED will start flashing, indicating that the machine has stopped running.

Maintenance and adjustment - Cleaning the filter

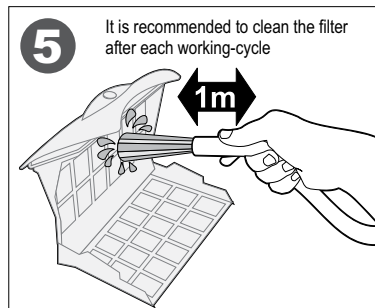
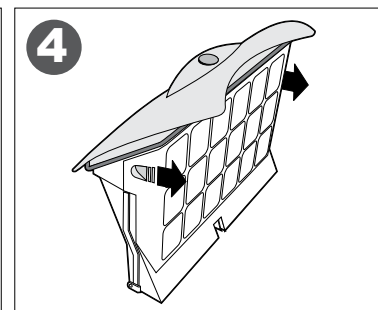
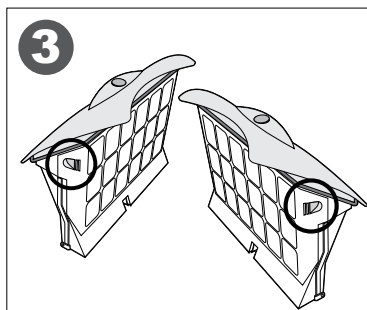
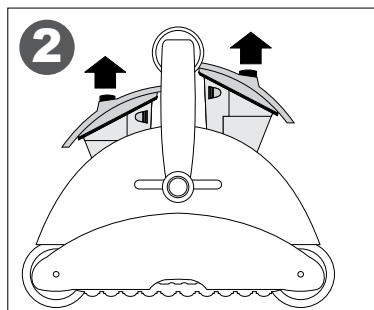
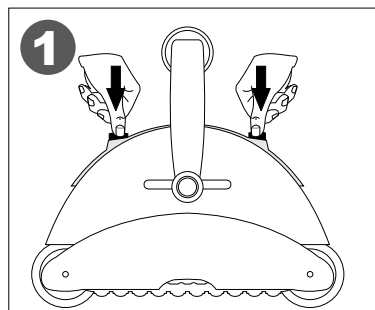

It is recommended to clean the filter after each working-cycle

1m

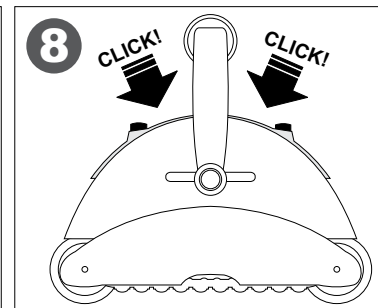
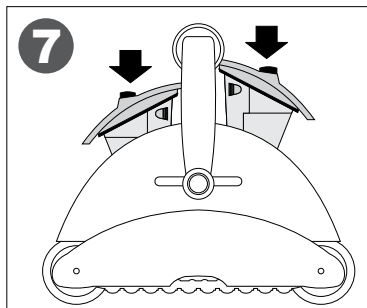
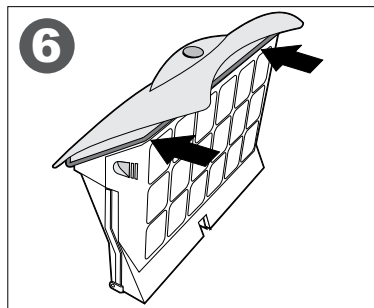

Adjusting the suction valve:

In order to increase suction power, the valves located underneath your cleaner can be adjusted by pulling out the rim of the valve.

Before lowering the rim of the valve, make sure there is enough clearance and the unit movements won't be obstructed by any obstacles on the swimming pool floor or walls, such as (drains, steps, etc.)

1) To pull out the rim rotate counterclockwise using a screwdriver (Fig. A)

2) To retract the rim rotate clockwise using a screwdriver (Fig. B)

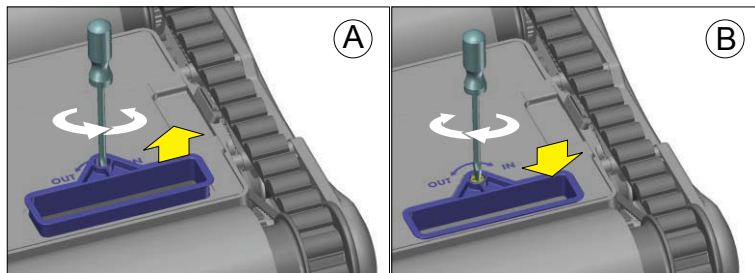

Cleaning the pump propeller:

1) Take out the screws from the outlet top

2) Take out the outlet top and remove hair and other debris around propeller

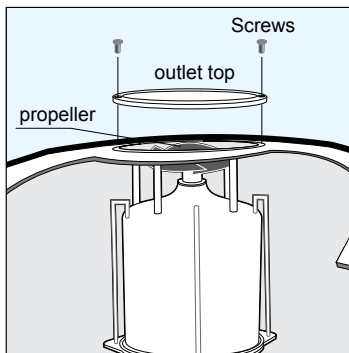
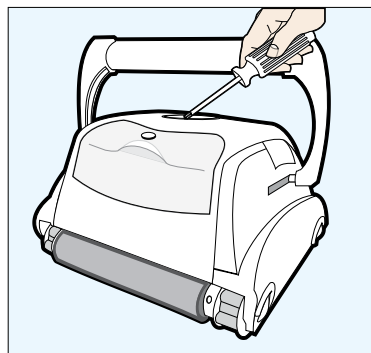

CABLE CARE

The cable may become twisted after a period of time in use. To correct this condition, simply lock the moveable handle on the top of the cleaner in the opposite diagonal direction. The pool cleaner will now travel in the opposite direction while cleaning your pool and the cable will uncoil. Check the cable periodically for external damage. If the problem persists, use the E-Z Swivel device.

Place the robot on the ground and unplug the cable from the transformer. With one hand, holding the E-Z Swivel, walk away from the robot, pulling the cable to its full length. The core will rotate inside the cover and in this way will untangle the cable.

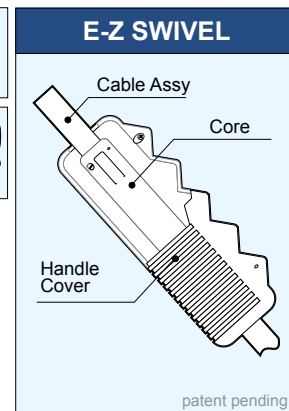
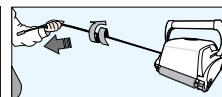
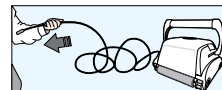

IMPORTANT TIPS:

- Shut off and unplug the power supply every time you remove the cleaner from the water.
- Clean the filter bag after every cycle.
- Periodically straighten out the floating cable.
- Replace worn brushes to ensure maximum cleaning performance
- Save your cleaner's packaging for off-season storage or for shipping the unit to your dealer if service is required.
- Leave your pool cleaner in the water for 15 to 20 minutes after every cleaning cycle.
- **Do not leave your cleaner in direct sunlight when not in use.**
- **Never leave the power supply in direct sunlight and avoid leaving it in the rain.**
- Occasionally, you should rinse your cleaner in clean, fresh water. This will lengthen the service life of the drive belts, drive tracks and scrubbing brushes.
- **Clean the propeller once a month**

CLIMBING UNITS WITH FLOATING HANDLE ONLY

- If your unit has floating handle, reverse the diagonal position after every cleaning cycle to avoid tangling the cable.
- Make sure that your pool cleaner positions itself properly on the wall. The machine handle must rest parallel to the water line upon reaching the surface of the water.

IMPORTANT:

Please be sure to always keep your pool cleaner properly stored anywhere between 10 to 40 degrees Celsius (50 to 104 degrees Fahrenheit). This will keep the motors, plastics and seals protected. Failure to comply will result in loss of warranty.

Robot can be used in water with temperatures ranging from 13°C to 35°C (55°F to 95°F). However, the recommended optimal temperature is between 22°C and 32°C (72°F and 90°F)

IMPORTANT:

The transformer cord can only be replaced with the aid of special tools, normally available only to authorized dealers, distributors and service centers.



Rainbow Pool Products

PO Box 2388, Mansfield Qld 4122

Telephone STD 61-7-3849 5385

Facsimile STD 61-7-3849 5384

Email: info@rainbowpoolproducts.com.au

Web: www.rainbowpoolproducts.com.au

PLEASE CHECK THE FOLLOWING BEFORE CALLING YOUR SERVICE CENTER

Before troubleshooting, the pool cleaner must be disconnected from the power supply and the power supply must be unplugged from the electrical outlet to prevent damage to the unit and possible personal injury.

1. Unit does not pump water or move:

- Check to see if electric outlet has power.
- Check if transformer is plugged into a grounded outlet and the grey cable assembly is plugged into the transformer.*
- Switch the power supply "OFF" and "ON" a few times. Allow 45 seconds between "ON" and "OFF".
- Check for and remove any debris such as hair, string, or leaves that may be obstructing the free movement of the Drive Tracks.

2. Unit does not pump water at all, or pumps slowly but moves:

- Check to see if propeller is seized due to accumulation of hair or debris on the propellers. Remove the top screws on each outlet top and clean the propeller. When reassembling the top cover, do not overtighten the screws.
- Check to see if the filter bags are thoroughly clean. Clean as necessary.
- If a and b are negative, check the pump motors. If they are not functioning send the unit to your service center.

3. Unit does not move but does pump water:

- Check to see if forward/reverse motion is obstructed by foreign matter; hair, debris, etc. on drive tracks or there is an entanglement with the power cord.
- Check for loose drive motor (3) connections.
- If a, and b are negative, check the Master motor (and Slave motor if equipped) motors. If one or the other is not functioning, send the unit to your service center.

4. Unit does not pick up dirt and debris:

- Check 2a and 2b of this guide.
- Check the Intake Valve Flaps on the underside of your unit (see image below). The Flaps should move freely to open and close. Clean and free the Valve Flaps if necessary.
- Check the height of the intake rim. If necessary, adjust the height with a screw driver (for details see previous page)

5. Unit does not seem to cover the entire pool:

- Most likely a thorough cleaning of the filter bags is needed.
- Check to see that the floating cable is properly spread out and is untangled.
- Allow the unit to run in the pool for the entire cleaning cycle.
- Make sure that the Floating Handle (if equipped) is locked diagonally across the top of your unit's body.
- Check that the Pump Motor is operating. Please refer to the section 2 of this guide
- After following all of the above, if there is still a problem, call your dealer for specific additional assistance.

6. Debris Comes Out Of The Unit When Removing It From Pool (Top Access Lid Does Not Close Properly)

- Lock Release - Check that the Lock release mechanism is not damaged. The lid edges should be aligned with the unit's body. Make sure the lid is engaged into the lock mechanism and snaps into place when inserted.
- Intake Valves - Check that the intake valve flaps on the underside of your unit (see image below) move freely to open and close. Clean flaps if necessary.

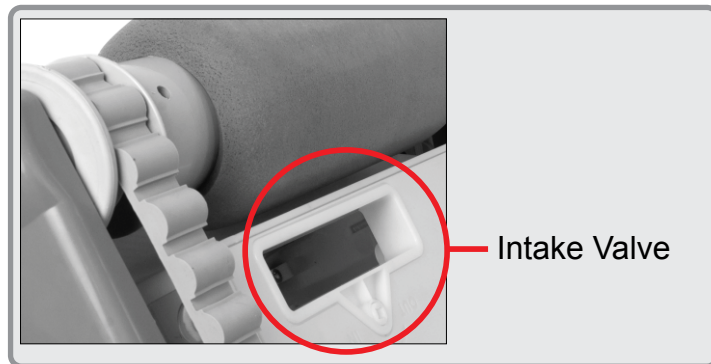

*The transformer cord can only be replaced with the aid of special purpose tools normally available only to authorized dealers, distributors and service centers.

WARRANTY TERMS AND CONDITIONS

Astral Pool Australia Pty Ltd (ABN 97 007 284 504) ("Astral Pool") provides the following warranty in relation to its Robotic Pool Cleaners.

Our goods come with guarantees that cannot be excluded under the Australian Consumer Law. You are entitled to a replacement or refund for a major failure and for compensation for any other reasonably foreseeable loss or damage. You are also entitled to have the goods repaired or replaced if the goods fail to be of acceptable quality and the failure does not amount to a major failure.

The benefits of this warranty are in addition to any rights and remedies imposed by Australian state and federal legislation that cannot be excluded. Nothing in this warranty is to be interpreted as excluding, restricting or modifying any state or federal legislation applicable to the supply of goods and services which cannot be excluded, restricted or modified.

Your Astralpool Robotic Pool Cleaner is covered by a limited 3 year warranty against defect in material and assembly.

| Parts | Warranty Period |
|---|-----------------|
| Robot Motor, Drives and Electrical System | 3 Years |
| Transformer | 2 Years |
| The rollers, tracks, pulleys, filter cartridge or bag | 1 Year |
| Caddy (if included) | 1 Year |

1. If a fault covered by warranty occurs, the customer must first contact AstralPool at the contact address listed below, or an Authorised AstralPool Service Agent.
2. Any warranty claim must be accompanied by:
 - (a) proof of purchase;
 - (b) full details of the alleged defect; and
 - (c) appropriate documentation (such as historical and maintenance records).
3. The customer must make the Product available to AstralPool or its Authorised AstralPool Service Agent for inspection and testing. AstralPool or its Authorised AstralPool Service Agent will attend the premises where the Product is installed for inspection and testing.
4. If such inspection and testing finds no defect in the Product, the customer must pay AstralPool's usual costs of service work and testing. If such inspection and testing finds a defect that is not covered by this warranty, the customer must pay AstralPool's usual costs of service work plus any parts and labour required to repair the Product, unless recoverable from AstralPool on the failure of any statutory guarantee under the ACL.
5. If your Robot Cleaner needs to be returned to Astralpool the following is required:
 - (a) Your Robot Cleaner must be packaged carefully including your name, address and contact number.
 - (b) Delivered freight prepaid to your nearest AstralPool Warehouse.
 - (c) You must also include a copy of your invoice showing date of purchase or date of handover of your swimming pool.
 - (d) Description of the fault.
6. For Service please return to your nearest AstralPool Trade Centre which can be found at:
<http://www.astralpool.com.au/contact>

EXCLUSIONS

The warranty will not apply where:

- (a) the customer is in breach of the Terms and Conditions of Sale;
- (b) the Product was used for a purpose other than one it was intended for;
- (c) the Product was repaired, modified or altered by any person other than AstralPool;
- (d) the Product has not been installed, maintained and/or operated in complete compliance with the installation and operating instructions and any instructions by AstralPool;
- (e) the Product has been subject to accident, negligence, alteration, abuse or misuse.

The warranty does not extend to:

- a) normal wear and tear;
- b) weather and other environmental conditions including but not limited to storm, flood, and/or heat wave damage; or
- c) service and maintenance items.

Examples of exclusions include but are not limited to:

- Incorrect installation
- External power spikes / surge
- Normal wear and tear of consumable parts such as rollers, pulleys, drive belts and filter cartridge/bag

LIMITATIONS

AstralPool makes no express warranties or representations other than set out in this warranty.

The repair or replacement of the Product or part of the Product is the absolute limit of AstralPool's liability under this express warranty.