



RAINBOW POOL PRODUCTS

Quality Pool & Spa Products

BX HIGH PERFORMANCE PUMP SINGLE PHASE



3 Year Warranty

Description:

Astralpool Australia's premier high performance pump. Huge hair and lint bowl with 170mm wide and 230mm deep basket, 65mm and 50mm unions included and whisper quiet operation. Ramp on lid lock ring for easy removal and positive sealing. True carbon face mechanical seal. Suitable for demanding applications and commercial pools and spas.

Ordering:

Please specify product number when ordering.

Warranty Guide:

Limited three (3) year warranty on all components. Refer to instructions and website for full warranty details

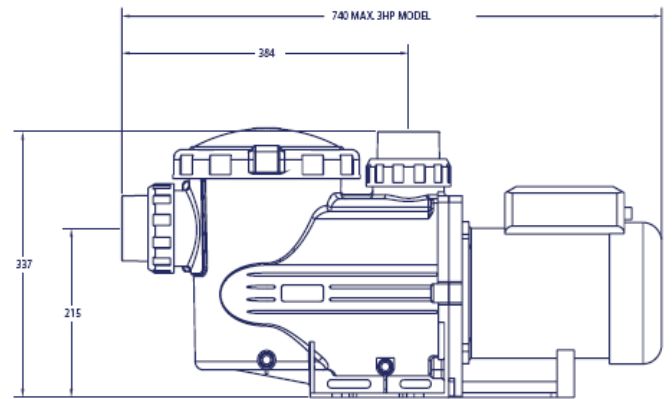

Model	Voltage	Phase	Input	Full Load
BX1.0	240	Single	1300	5.5
BX1.5	240	Single	1640	6.6
BX2.0	240	Single	2020	8.5
BX3.0	240	Single	2300	12.5

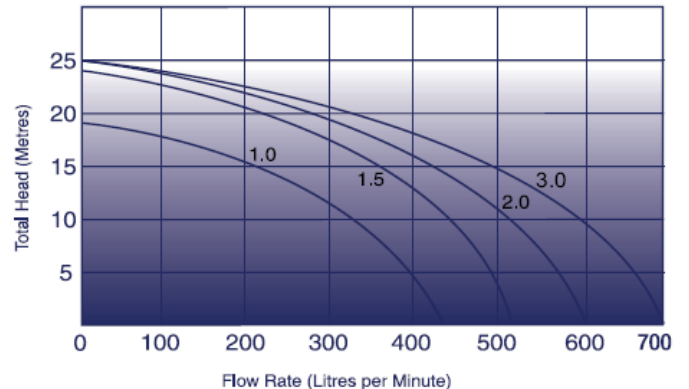

BX 1.0 High Performance Pump
 BX 1.5 High Performance Pump
 BX 2.0 High Performance Pump
 BX 3.0 High Performance Pump

Product Code	Flow Rate @ 8 m/h	Max Noise Level @ 1 mtr
--------------	-------------------	-------------------------

11491	325 lpm	60 dBA
11492	440 lpm	60 dBA
11493	540 lpm	62 dBA
11494	635 lpm	62 dBA