



BX HIGH PERFORMANCE PUMP - THREE PHASE



3 Year Warranty

Description:

Astralpool Australia's premier high performance pump.

Ordering:

Please specify product number when ordering.

Warranty Guide:

Limited three (3) year warranty on all components. Refer to instructions and website for full warranty details

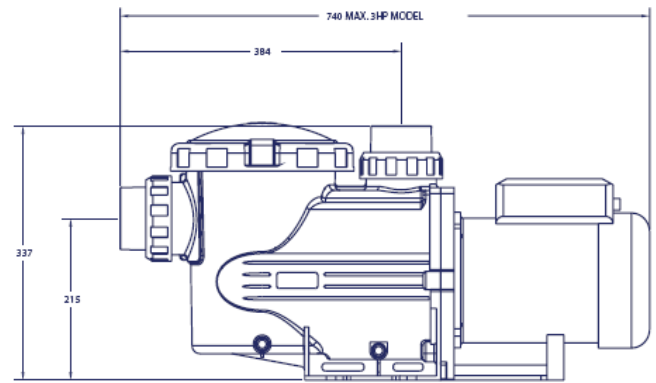

Model	Voltage	Phase	Input	Full Load
BX1.0	415	Three	1300	1.9
BX1.5	415	Three	1640	2.1
BX2.0	415	Three	2020	2.6
BX3.0	415	Three	2300	3.1

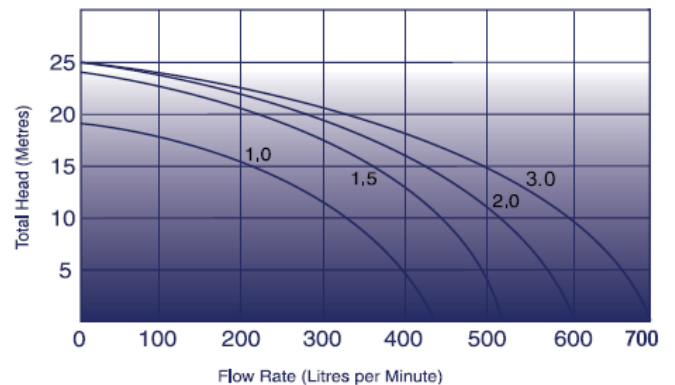

Product Code	Flow Rate @ 8 m/h	Max Noise Level @ 1 mtr
--------------	-------------------	-------------------------

BX 1.0 - 3 Phase High Performance Pump	11496	325 lpm	60 dBA
BX 1.5 - 3 Phase High Performance Pump	11497	440 lpm	60 dBA
BX 2.0 - 3 Phase High Performance Pump	11498	540 lpm	62 dBA
BX 3.0 - 3 Phase High Performance Pump	11499	640 lpm	64 dBA