

FLOW CONTROL TIMER



CODE

DCC240

DESCRIPTION

Booster Pump Timer Control with Flow Switch

INSTALLATION & OPERATING INSTRUCTIONS MODEL DCC 240

INSTALLER – READ ENTIRE INSTRUCTION SHEET BEFORE PROCEEDING TO INSTALL.

POOL OWNER – PLEASE KEEP THESE INSTRUCTIONS FOR FUTURE REFERENCE.

Flow Control Box Mounting

Find a suitable location to mount the Flow Control Box. Ideally, as with all pool equipment, it should be protected from direct weather and no closer than 3m from the waters edge.

Lift up the two mounting tabs and use the two screws provided to mount the Flow Control Box to the wall.

If using the supplied green wall plugs, then use a 6.5mm masonry drill bit. Keep in mind that the Flow Switch sensor cable is 2.4m long. The Flow Control Box Power Cable is 1.8m long and should be plugged directly into a constant 240v power outlet. Do not use an extension lead, and do not plug the Flow Control Box Power Cable into a time clock, a chlorinator or a time clock-controlled power point. Booster Pump Power Cable is plugged into the underside of the Flow Control Box, but don't turn anything on just yet.

Flow Switch and Faucet Tee

The Flow Switch has a $\frac{3}{4}$ " BSP thread, and screws into a Cat 21 Faucet Tee, don't screw it in just yet. The Faucet Tee may be 40mm or 50mm, depending upon the pipework. Carefully choose a position in the pipework to glue in the Faucet Tee. The Faucet Tee must be installed **after the filter** and **before the booster pump take-off tee**, it can be installed in vertical or horizontal pipework. Refer to the diagram below to ascertain the correct location of the Faucet Tee. Other installation diagrams appear in this document.

Installing Flow Switch

Once the Faucet Tee has been glued into position, apply thread tape and silicone sealant to the Flow Switch and screw it into the Faucet Tee. The orientation Arrow on top of the Flow Switch must align with the water flow direction in the pipework. Plug the Flow Sensor Cable into the green socket on the underside of the Flow Control Box.

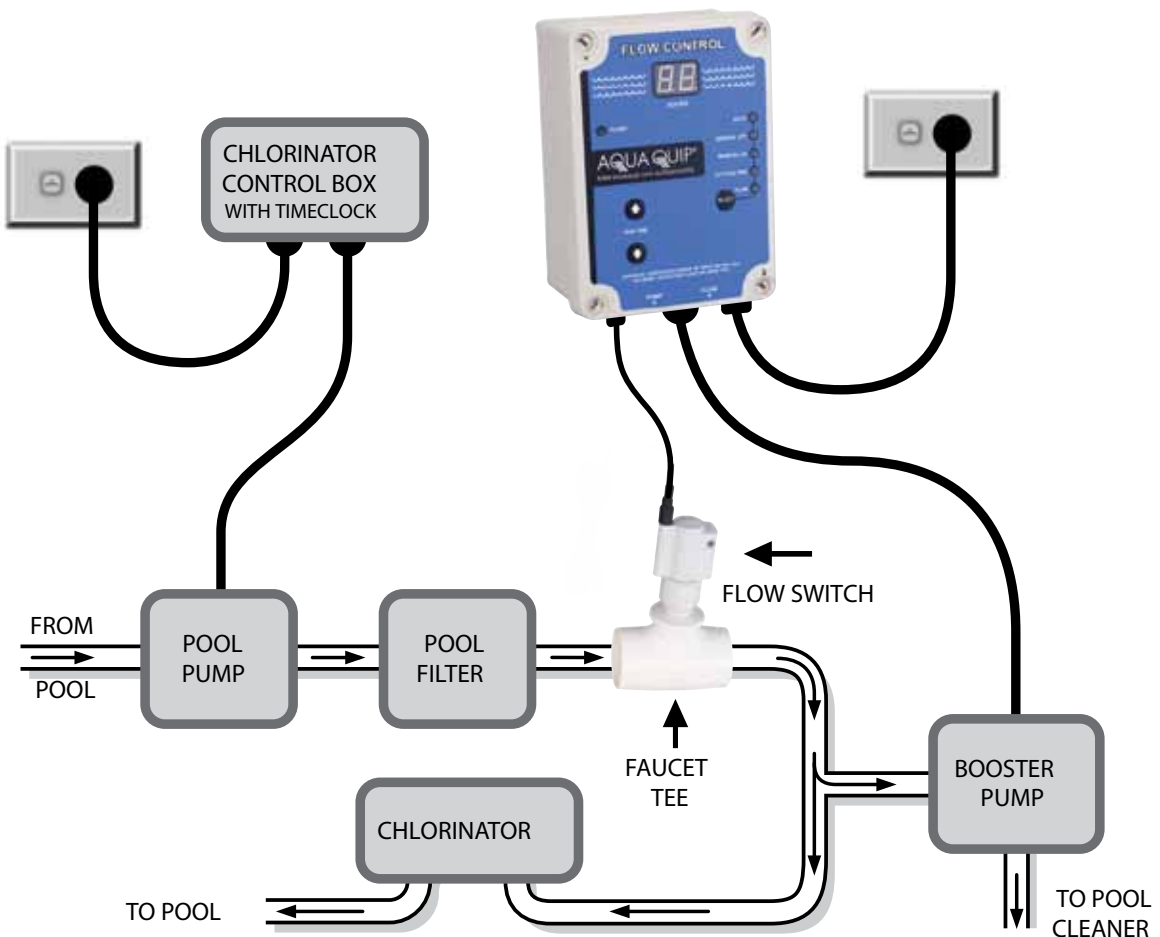

FLOW CONTROL TIMER

OPERATING INSTRUCTIONS

The Flow Control Timer will provide power to a Booster Pump for the user-defined period of time when constant water flow is detected by the Flow Switch located in the pipework. Once the Installation is complete, leave sufficient time for glue to dry before starting the system up. Turn the Flow Control Timer on at the power point (leave the Pool Pump off), the AUTO light will come on and 2.0 hours will be lit.

Set the Run Time

Each time the Pool Pump turns on and provides water flow to the Flow Switch, the Booster Pump will turn on for the amount of hours that has been programmed. Therefore, if the Pool Pump runs for more than one cycle per day, take this into account when selecting your required cleaner running times. See the examples in the table below..

Pool Pump Timer Cycles (per day)	Pool Pump Timer Hours	Hours Selected for Booster Pump	Booster Pump Operation Times	Total Booster Pump Hours per day
2	8am-11am 2pm-6pm	1	8am-9am 2pm-3pm	2
1	8am-5pm	3	8am-11am	3
2	8am-1pm 4pm-8pm	2	8am-10am 4pm-6pm	4
3	8am-11am 1pm-4pm 5pm-9pm	1	8am-9am 1pm-2pm 5pm-6pm	3

The **SELECT** button allows you to scroll from **AUTO** through to **SET RUN TIME**. Press the **SELECT** button until the **SET RUN TIM** button is lit, then press the **UP** and **DOWN** buttons to adjust the run time in half-hour (0.5) intervals. The range is from 0.0 hours (disabled) to 5.0 hours. Once you have selected the required run time, press the **SELECT** button until the **AUTO** light is lit. This is now your Default Run Time. The Flow Control Box will remember this run time, until you program something new.

Congratulations, you have now programmed your Flow Control Timer. Keep the Flow Control Timer plugged in to a continuously operated power point.

Automatic Mode

Ensure your Flow Control Timer is on, and the **AUTO** light is lit. Turn on your Pool Pump. When the Pool Pump primes and starts pumping, the **FLOW** light will start flashing for 30 seconds before switching on the Booster Pump for the user-selected time period. When the Booster Pump is on, the **PUMP** light is lit. Leave the Flow Control Timer in **AUTO** mode for "set and forget" functionality. As the Booster Pump operation hours run down, the **DISPLAY** shows 2.0 then 1.5 then 1.0 etc which indicates run time remaining. Once the Booster Pump operation hours finish, the **DISPLAY** shows 0.0. The display will remain displaying 0.0 until the Pool Pump starts up again and provides flow, whereupon the Default Run Time will be displayed.

Manual Off

MANUAL OFF is selected by pressing the **SELECT** button until the **MANUAL OFF** light is lit.

This turns the Booster Pump off indefinitely and prevents it from starting, even if **FLOW** is detected. The display will go blank and the **MANUAL OFF** light will then flash.

Manual On

MANUAL ON is selected by pressing the **SELECT** button until the **MANUAL ON** light is lit.

A) If **FLOW** is detected when the **MANUAL ON** button is pressed, the Booster Pump will switch on and the **MANUAL ON** light will flash. When the Pool Pump times out, **FLOW** will stop and the Booster Pump will switch off. The Flow Control Timer will revert back to **AUTO** mode.

B) If **FLOW** is not detected when the **MANUAL ON** button is pressed, then the Booster Pump will not switch on and the Flow Control Timer will revert back to **AUTO** mode.

Setting a new Run Time

To set new run times, the **SET RUN TIME** light must be lit (as described above), and then left in **AUTO** mode.

If the **UP** and **DOWN** buttons are pressed whilst the Flow Control Timer is in **AUTO** mode, then the selected running time will only work for the one time only, then the Flow Control Timer will revert back to the user selected default hours.

FLOW CONTROL TIMER

PARTS DESCRIPTIONS

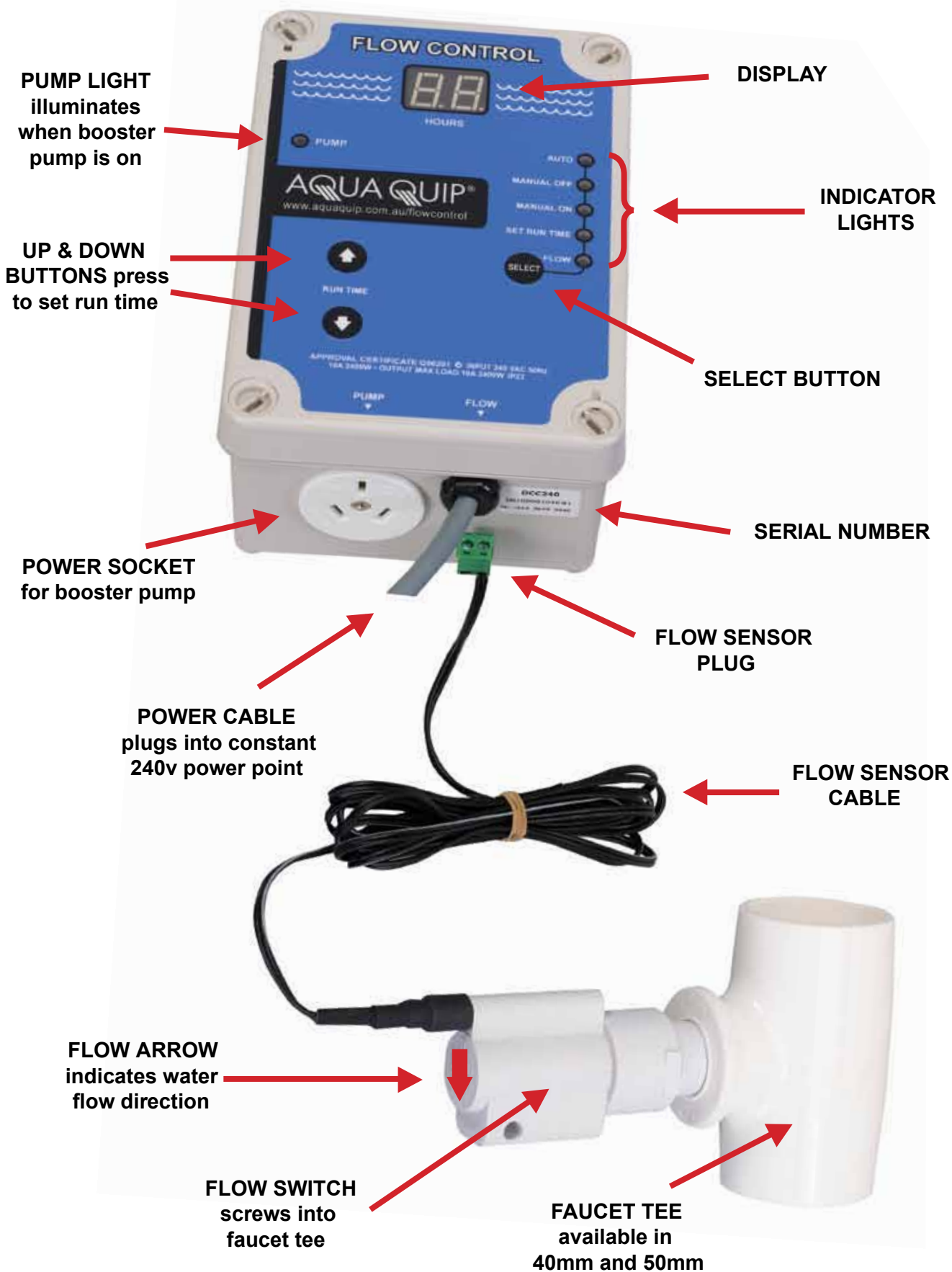

FLOW CONTROL TIMER

POOL DIAGRAM

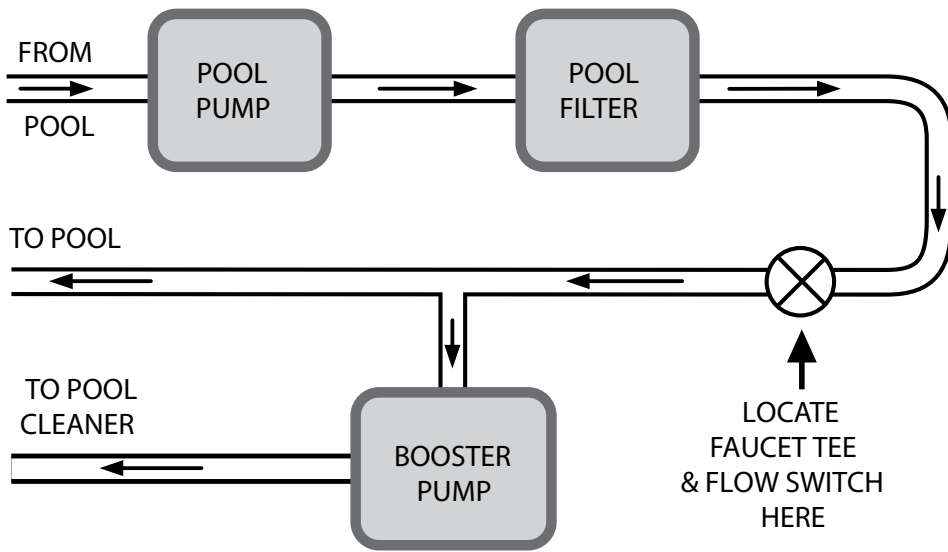

POOL DIAGRAM

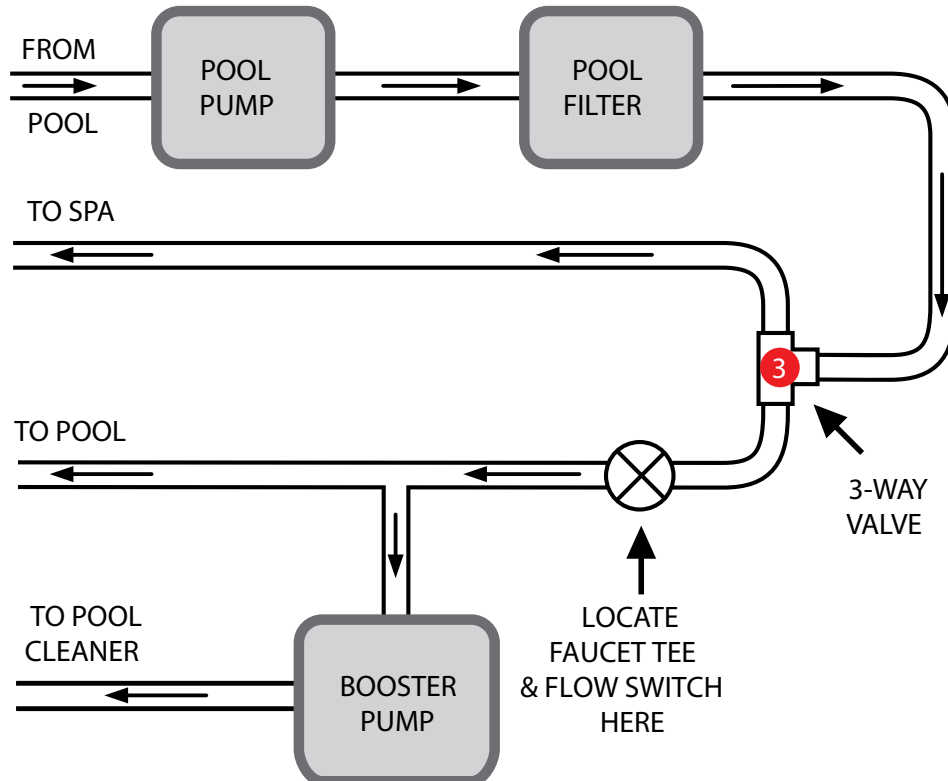

Rainbow Pool Products

PO Box 2388, Mansfield Qld 4122

Telephone STD 61-7-3849 5385

Facsimile STD 61-7-3849 5384

Email: info@rainbowpoolproducts.com.au

Web: www.rainbowpoolproducts.com.au