

COUNTER-CURRENT SWIMMING

Hurricane Turbo Swim Jet

INSTALLATION INSTRUCTIONS

PACKET NO.1



Rainbow Pool Products

PO Box 2388, Mansfield Qld 4122

Telephone STD 61-7-3849 5385

Facsimile STD 61-7-3849 5384

Email: info@rainbowpoolproducts.com.au

Web: www.rainbowpoolproducts.com.au

With a COUNTER-CURRENT SWIMMING device your swimming pool is no longer a simple man-made lake. It becomes the most appealing place to be, an amusement park, a place to have fun and become fit.

A COUNTER-CURRENT SWIMMING device transforms your swimming pool into a water torrent and gives you general and localized hydrotherapeutic massages.

The high-powered pump of the COUNTER-CURRENT SWIMMING device pumps up water from the pool and pushes the water back into the pool forcefully, together with millions of air bubbles which optimise your massages.

FIBREGLASS/VINYL

CUT-OUT OF THE PANEL:

Place the pattern on the inside panel taking the 400 mm linear dimension between the axis XY and the top of the structure into account.

Caution: Make sure you position axis XY parallel to the top of the structure.

Mark the 14 mounting bolt holes on the panel and cut out the pattern according to the points.

Trace the profile on the panel and carry out the cutting and drilling.

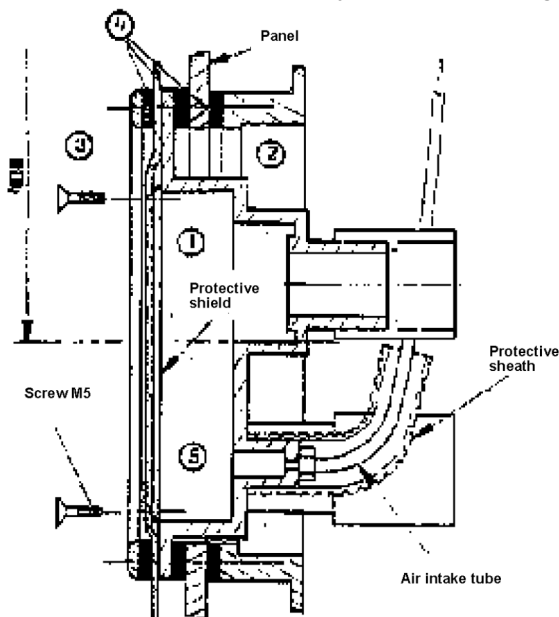
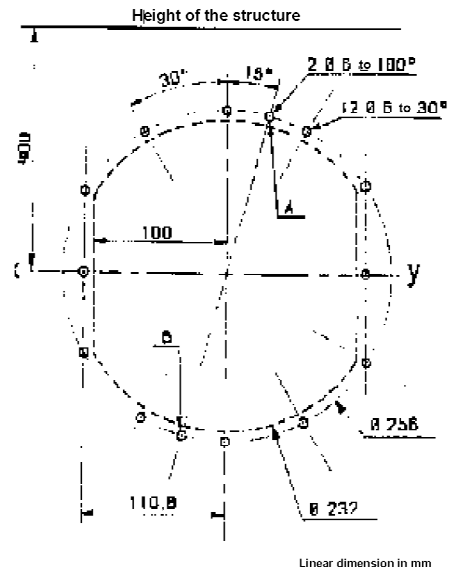

MOUNTING OF PACKAGE 1 ON THE PANEL:

1- Fitting of the 3 self-adhesive Gaskets:

- Clean the surface and then stick Gasket (4) to the Counter Flange (2).
- Clean and then stick Gasket (4) to the back of the Jet Body (1).
- Clean and then stick Gasket (4) to the flat side of the Flange.

2- Mounting of the Protective Shield:

Mount the Protective Shield (5) using the 3 screws M5 which prevent any kind of deformation of the liner.

3-Mounting of the Jet Body:

Hold the Counter Flange (2) to the outer side of the panel. Place the Jet Body (1) on the other side of the panel and keep everything in place by using the 2 fixing screws in A and B.

4-Fixing Bracket for Fibreglass/Vinyl Pools:

After having placed the liner, fill the pool to the base of the Jet Body. Place the Bracket opposite the Jet Body and place the 12 screws (the liner is simply pierced by the screws). Tighten it enough for the joint to be well fixed into place but avoid using excessive force. If you are installing package 2 (= front) immediately, cut the liner with a cutter, otherwise leave in tact.

CONCRETE

DRILLING:

Position the pattern on the inside casing taking the 400 mm linear dimension between the axis XY and the top of the structure into account.

CAUTION: Make sure you position axis XY parallel to the top of the structure.

Pierce the 2 mounting bolt holes of 6 mm diameter in A and B.

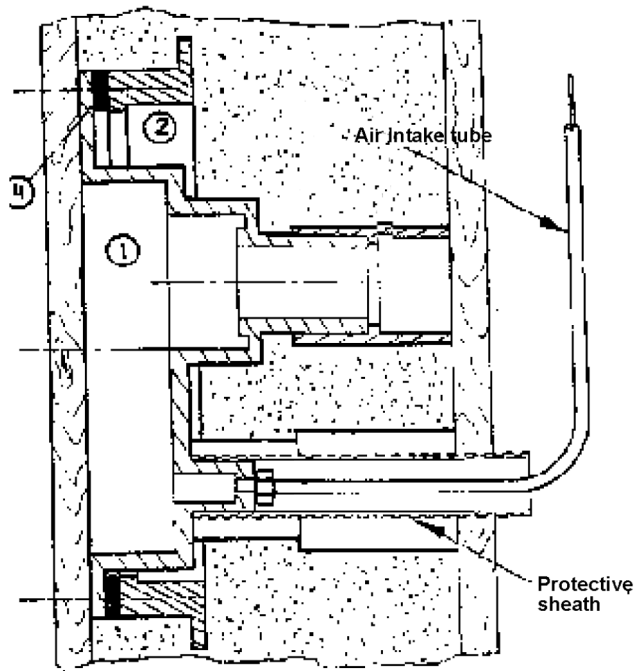
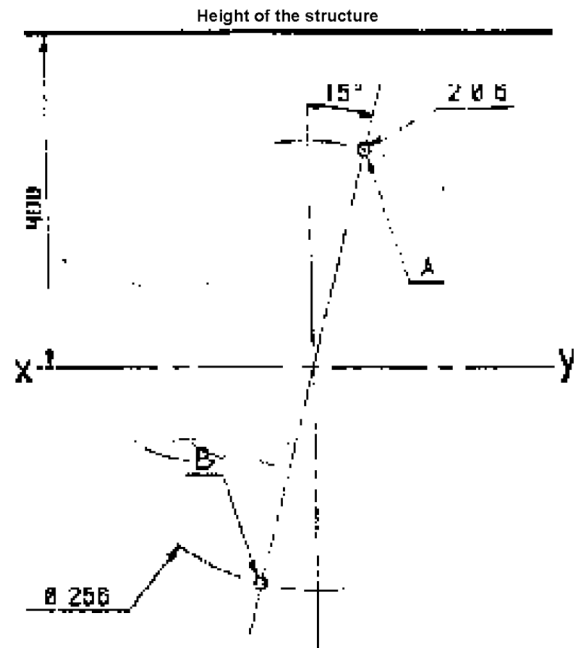

MOUNTING OF PACKAGE 1 ON THE JET BODY:

1. Placing of the self-adhesive Gasket:

Clean the pre-drilled side of the Counter Flange (2) then stick Gasket (4) to Counter Flange.

2. Mounting of the Jet Body:

Place the Counter Flange (2) at the rear of the Jet Body (1) and fix the whole device to the inside casing by using the 2 fixation screws A and B.

Make sure the outer casing is fixed to the sleeves so that the concrete cannot enter. If this is not the case, use a piece of polystyrene to fill the gap.

CAUTION: Fix the air intake pipe against the wall of the premises, **above water level**, by using the hook provided for said purpose.

LOCATION OF THE PRESSURE REGULATOR:

If your electrical equipment box is more than 5 metres away from the front face, you should bring the pressure regulator (interrupter of the pneumatic button) close to the swimming pool in a connection box.

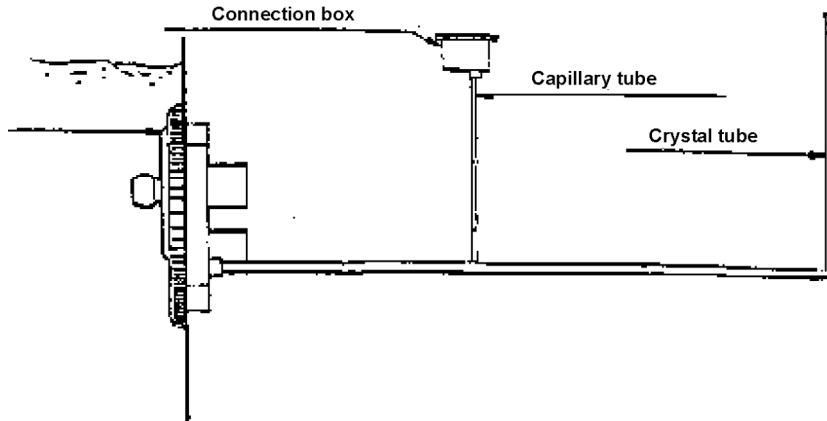

POSITIONING OF THE PUMP:

The pump of this device must be installed next to the structure and must be connected by a pressure pipe, minimum diameter 50mm.

If this is not possible the pump can be placed further away, although the loss of pressure/flow must be calculated for. Refer Table below.

Distance between the front face and the pump	Diameter of the pipes
1m	Diameter 50mm (2")
1 to 5 m	Diameter 65mm (2.5")
5 to 15 m	Diameter 80mm (3")

PACKAGE NO.2

Additional components:

Ergonomic Jet Face.
Adjustable Air Outlet Valve.
Pneumatic Start-Up Control.

PACKAGE NO.3

Single-phase or Three-phase Hydro-Electric Generating Set.

PACKAGE NO.4

Single-phase or Three-phase Switch Box (with Thermal Relay adapted in accordance to the choice of Hydro-Electric Generating Set).

Hurricane Turbo Swim Jet

INSTALLATION INSTRUCTIONS

PACKET NO.2



Rainbow Pool Products

PO Box 2388, Mansfield Qld 4122

Telephone STD 61-7-3849 5385

Facsimile STD 61-7-3849 5384

Email: info@rainbowpoolproducts.com.au

Web: www.rainbowpoolproducts.com.au

With the HURRICANE TURBO SWIM JET your swimming pool is no longer a simple man-made lake. It becomes the most appealing place to be, an amusement park, a place to have fun and become fit.

The SWIM JET transforms your swimming pool into a water torrent and gives you general and localized hydrotherapeutic massages, as well making counter-current swimming possible.

The high-powered pump of the SWIM JET pumps up water from the pool and pushes the water back into the pool forcefully, at the same time as millions of air bubbles are propelled by the JET, bringing you power, oxygen and tonification.

MOUNTING OF PACKAGES 2, 3, 4

- Make sure the 12 screws of the flange are correctly fastened without using excessive force.
- Cut out the liner along the inside of the flange by using a cutter.
- Remove the protective shield attached to the Jet Body with three M5 screws length 10.

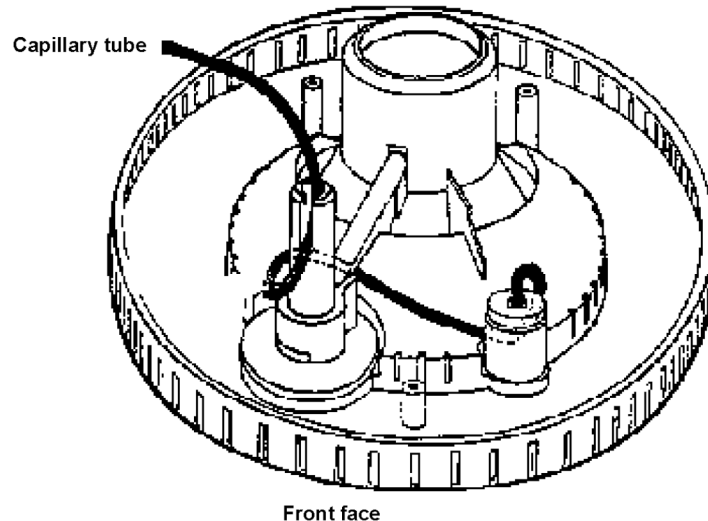

CONNECTING:

-Connect the small capillary tube to the back of the Control Button, and pass it under the air intake pipe, then through the slit foreseen for this purpose on the Air Regulation Button.

-Now slide capillary tube through reinforced hose connected to Jet Body.

CAUTION: the far end of the air intake pipe must be placed above water level.

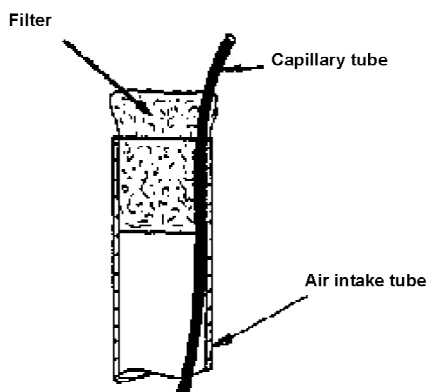

-Do not forget to place the blue tube filter at the far end of the air intake pipe.

-Fix the air intake pipe to the wall of the premises using hook provided.

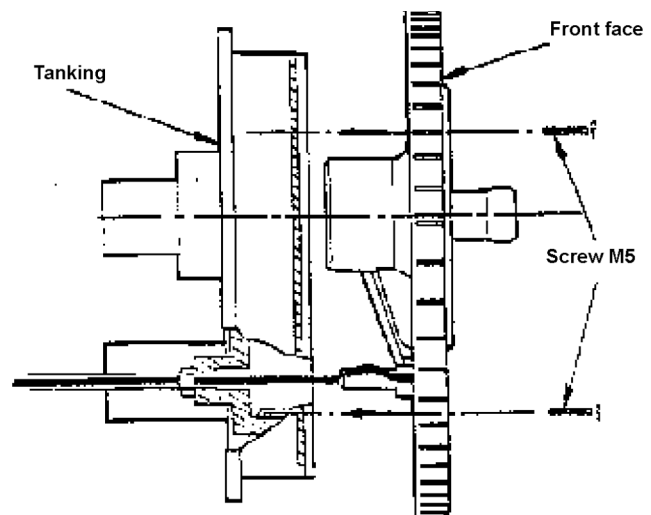

FIXING JET FACE:

-Once all previous instructions have been carried out, screw the Jet Face to the Jet Body by using three fixation screws M5 length 30.

CONNECTION TO THE SWITCH BOX

POSITIONING OF THE PRESSURE REGULATOR:

If your electrical equipment box is more than 5 metres away from the Jet Face, the Pressure Regulator (interrupter of the pneumatic button) should be moved closer to the swimming pool in a connection box.

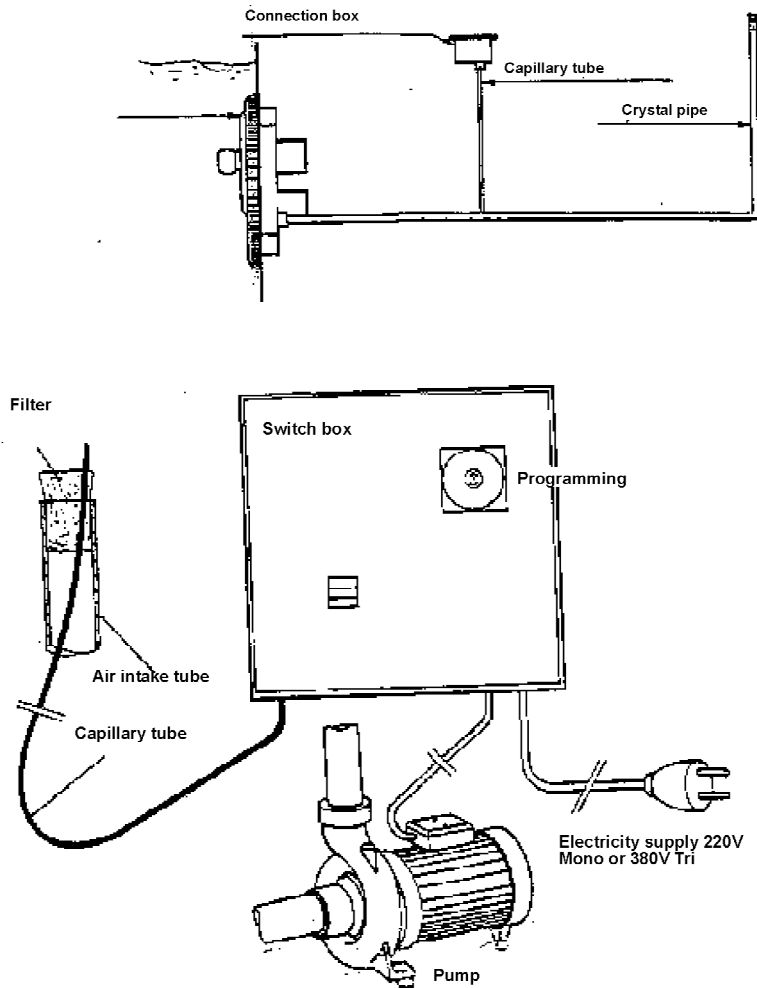

WINTER STORAGE:

(Only required in countries with temperatures below 0 degrees Celcius)

- Disconnect the capillary tube from the switch box.
- Dismantle the Jet Face and remove the whole device.
- Place the two tapered stoppers in the two openings of the Jet Body.
- Turn thumb screw until stopper has expanded adequately to ensure seal is watertight

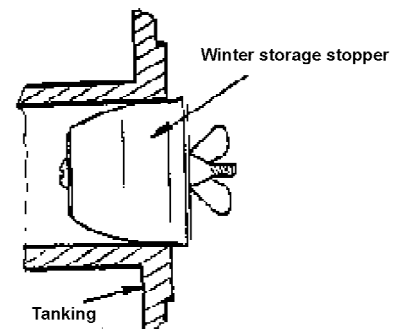

Swim Jet

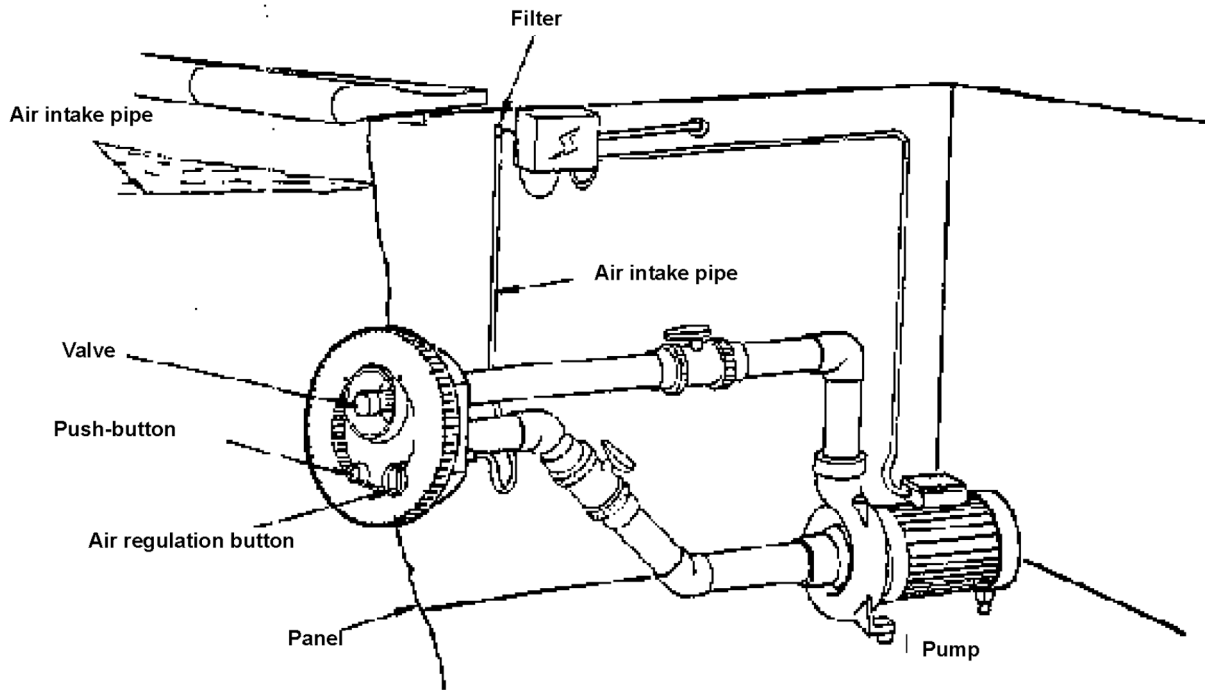

- The push-button is used to turn on the device by applying light pressure to the button.
- The other button is used to regulate the output of air from the valve, allowing more or less air to be propelled from the valve.
- CAUTION: Do not forget to close this air button after having used the massage pipe which is fitted on the valve (optional accessory).

REGULATING THE VALVE:

You can regulate the direction of your jet as well as the output of air from the valve by simply turning the valve one quarter.

Basic Components:

(to be foreseen at the time of construction)

- Jet Body
- Flange and Counter Flange with Gaskets
- Shut-Off Valves
- Air Intake

Additional Components:

- Ergonomic Jet Face
- Adjustable Air Output Valve
- Pneumatic Start-Up Control
- Switch Box

Optional Accessories:

Massage Pipe

