



DAVEY

APPLICATIONS

Ideal for most swimming pool applications such as:

- Lap pools
- Concrete and tile pools
- Fibreglass pools
- Swim Jet installation
- Sport or rehabilitation installations

WHY CHOOSE THE Hurricane® turbo swim jet system?

Maximises the value and enjoyment of your pool.

High powered pump provides a high flow jet of water to swim against.

Swim jet controlled by air switch on swim jet. No need to leave the pool to turn on or off.

Turbo swim jet outlet provides 3 settings for jet flow control.

Simple installation of swim jet – only one hole required for both suction & return points.

Designed for dependability and long life using corrosion resistant, UV stabilised materials.

Self priming up to 4 metres for easy operation and installation.

Stainless steel pump shaft suited for salt chlorinated pools.

65mm barrel unions for easy installation to large OD pipe.

65-80mm PVC adaptors also available for easy connection to DN80 pipe – M3689.

2 Year guarantee.



DAVEY

Hurricane®

Turbo Pump & Swim Jet System

Has the power to turn your swimming pool into a practical sport and leisure zone, with a counter-current swim system.



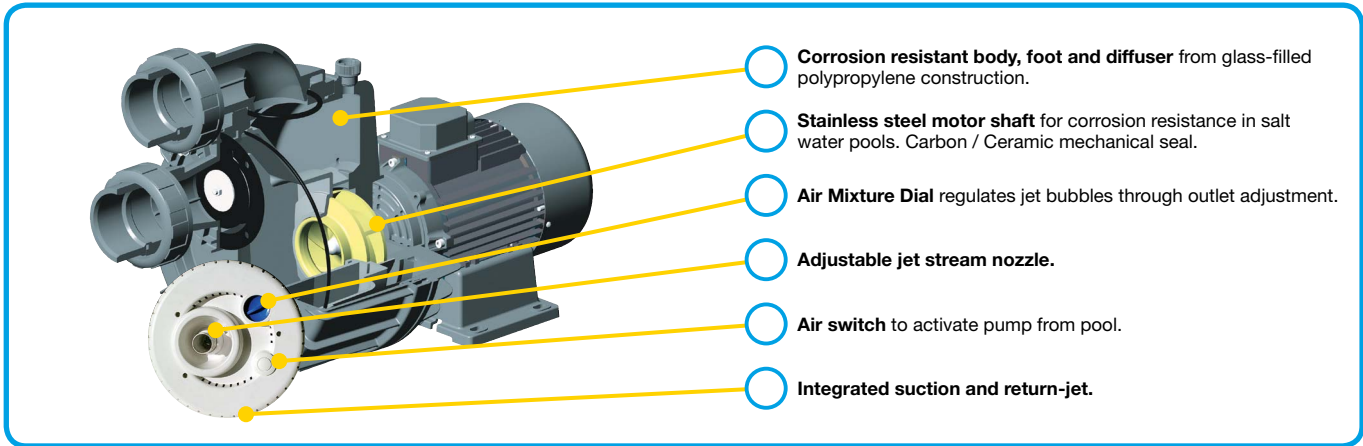

ELECTRICAL DATA	
Model	Hurricane 300
Voltage (V)	220-250
Supply Frequency/Phase	50Hz / 1
Run Current (A)	12.5
Motor Input Power (W)	3000
Motor Output Power (W)	2300
RPM	2900
Enclosure Class (IP)	55
Insulation Class	F
Approval No.	W2442

OPERATING LIMITS	
Maximum water temperature	35°C
Maximum ambient temperature	50°C

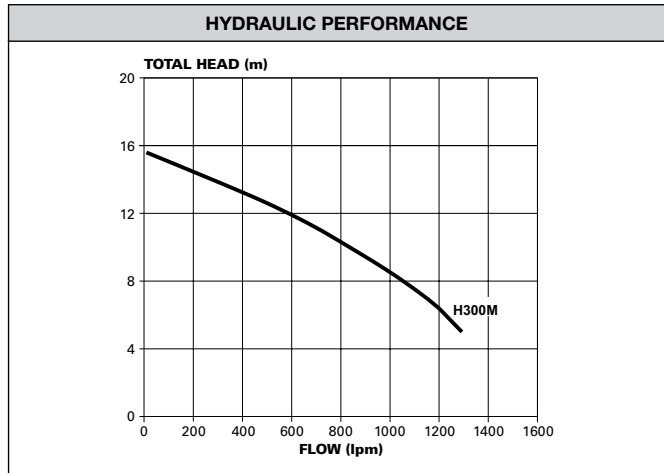

DIMENSIONS (mm)								
Type	A	B	C	D	E	F	G	Net Weight (Kg)
H300M	615	335	414.6	195	247	130	65	26

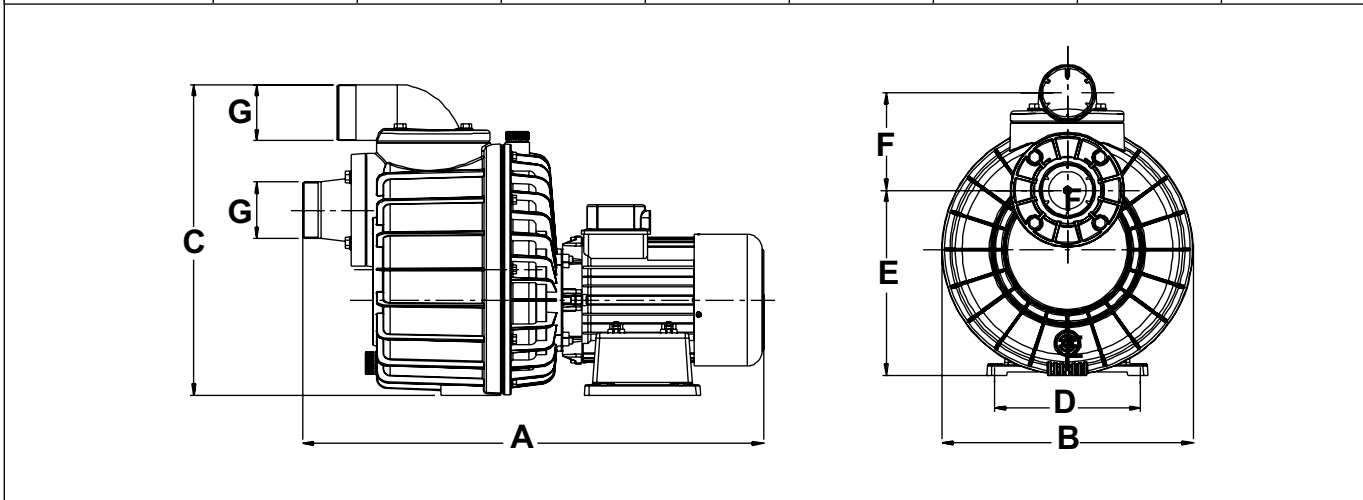

Rainbow Pool Products

PO Box 2388, Mansfield Qld 4122

Telephone STD 61-7-3849 5385

Facsimile STD 61-7-3849 5384

Email: info@rainbowpoolproducts.com.au

Web: www.rainbowpoolproducts.com.au